



Headquarters

Viale Europa, 75
36075 Montecchio Maggiore
Vicenza | Italy

info.acousticdevices@fiammcomponents.com
www.fiammcomponents.com

Production Plants

ITALY
Via Dovaro, 8 - 36045 Almisano di Lonigo (VI)

CZECH REPUBLIC
Nádražní 1436, 293 01 Mladá Boleslav

CHINA
Han Nan Road 458, Shamao Town,
Hannan District, 430090 Wuhan City,
Hubei Province

U.S.A.
1550 Leeson Ave., Cadillac, MI

BRAZIL
Av. Piraporinha, 121 - CEP 09891-0000
São Bernardo do Campo SP

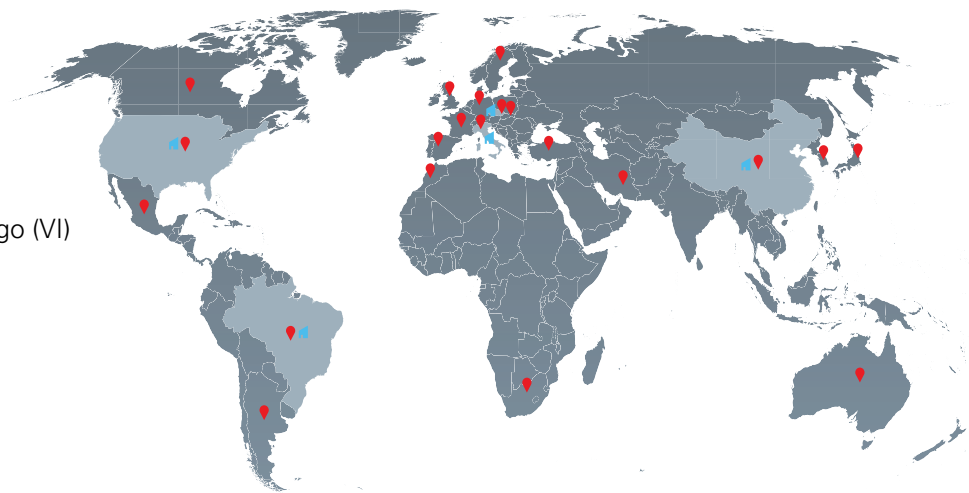

O.E. Customers

- | | | |
|----------------|----------------|-----------------|
| • Alfa Romeo | • Mazda | • Caterpillar |
| • Aston Martin | • Mercedes | • Iveco |
| • Audi | • MINI (BMW) | • MAN |
| • BMW | • Mitsubishi | • Renault Truck |
| • BYD | • Nissan | • Scania |
| • Chrysler | • Opel (GM) | • Volvo Truck |
| • Citroën | • Peugeot | |
| • Ferrari | • Renault | |
| • FIAT | • SEAT | |
| • Ford | • Škoda | |
| • GM | • Toyota | |
| • Hyundai | • Vauxall (GM) | |
| • Jaguar | • Volvo | |
| • Lancia | • VW | |
| • Land Rover | | |
| • Maserati | | |



Certifications



www.fiammcomponents.com/Horns

THE WORLD'S LARGEST
MANUFACTURER OF CAR HORNS

ELECTROMAGNETIC

The sound is produced through an electro-magnetic circuit that forces a membrane to vibrate at high frequency.

Horns

Discs



ELECTRONIC

Frequency is controlled by an electronic circuit, leading to an increased product lifespan (high usage markets).

Horns

Discs



AIR HORN

The sound is produced when compressed air passes through an acoustic trumpet.

Pneumatic

Solutions operating with the on-board air system of the vehicle.

Electropneumatic

Solutions equipped with a compressor and a set of trumpets.



EMERGENCY SOLUTIONS

Acoustic warning systems for priority and emergency vehicles.

Electronic

Acoustic system for continuous service, composed by an electronic control unit and a set of loudspeakers.

Electropneumatic

Acoustic system composed by a compressor and a set of trumpets.

Pneumatic

Acoustic system composed by an electronic control unit and a set of trumpets.



FIAMM horns are produced in the same production plants where also original equipment horns are manufactured, using the same technology, manpower, equipment and control systems approved by car manufactures.

Gli avvisatori acustici FIAMM sono prodotti negli stessi stabilimenti produttivi dove vengono realizzati anche gli avvisatori di primo impianto, utilizzando la medesima tecnologia, manodopera, impianti e sistemi di controllo approvati dai costruttori di autoveicoli.

Las bocinas FIAMM se producen en las mismas plantas de producción donde se realizan también los avisadores acústicos de equipo original, utilizando la misma tecnología, mano de obra, maquinaria y sistemas de control aprobados por los fabricantes de automóviles.

Les avertisseurs acoustiques FIAMM sont fabriqués dans les mêmes usines de production où se produisent aussi les avertisseurs pour le marché de l'équipement d'origine, en utilisant les mêmes technologie, main d'œuvre, équipements et systèmes de contrôle approuvés par les constructeurs automobiles.

Die FIAMM akustischen Signaleinrichtungen werden in denselben Produktionsstätten hergestellt, wo auch die Hupen für den Erstausrüstungsmarkt gefertigt werden. Dieselben von den Fahrzeugherstellern genehmigten Technologie, Arbeitskräfte, Maschinen und Kontrollsysteme werden benutzt.

5 Automotive

Passenger Cars & Light Vehicles

Truck & Bus

Motorbike

19 Industrial & Heavy Duty

29 Emergency

System Overview

PS10 System

MC4 System

PS20 System

49 Marine

55 Miscellaneous

Adapters

Connectors

M4line / MC4 line / MC4 +

Accessories

NOVELTY line

GAS line

Contents

Automotive

6	AM80 line
10	HK line
11	TR99 line
12	JERICHO line / FA 260
13	TIR line / Fultone / TC2 line
14	M4 line / MT line / Ultimate Blast
16	Ala line
17	LLH line
18	BA line / BK line

Industrial & Heavy Duty

20	HK line / HK9E line
22	AM80 line
23	LLH line
24	JERICHO line
25	TIR line
26	M4 line / MT line / Ultimate Blast
28	BA line / BK line

Emergency

30	PS10 System Choice
32	MC4 System Choice
34	PS20 System Choice
36	PS10 System
42	MC4 System
44	PS20 System
46	Trumpets

Marine

50	VEGA line
51	MARINE HORN line
52	TA line

Miscellaneous

56	Adapters
57	Connectors
58	M4 line / MC4 line / MC4+ line
60	Accessories
62	NOVELTY line
64	GAS line
66	Packaging
68	Brackets

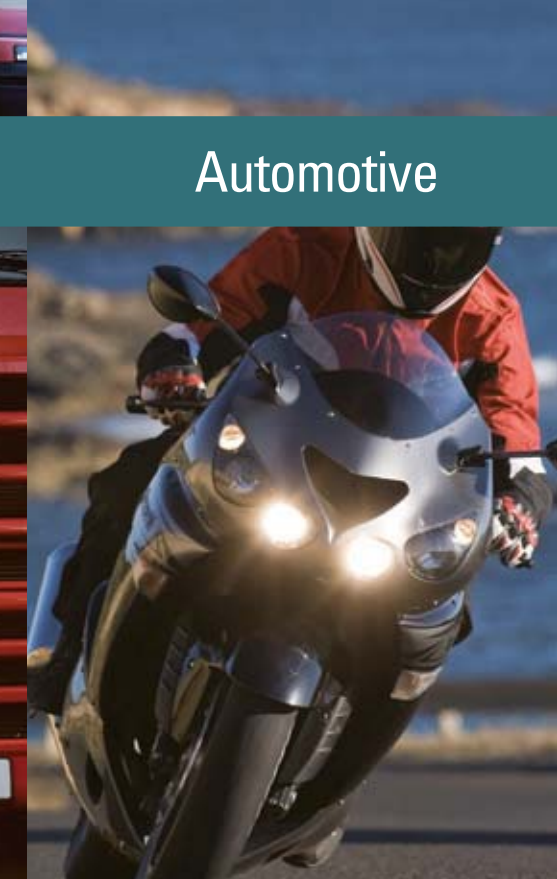

Automotive

Passenger Cars
& Light Vehicles
Truck & Bus
Motorbike

FIAMM

AM80 line

THE ORIGINAL EQUIPMENT BEST CHOICE
more compact more powerful

Compact emergency horn approved for road use. The most commonly installed by car manufacturers.

Avvisatore omologato a corsetto di ridotte dimensioni per uso stradale. Il più installato dai produttori di autoveicoli.

Bocina de caracol homologada, de dimensiones compactas, para el uso por carretera. La bocina más instalada por los fabricantes de automóvil.

Avertisseur homologué, de petite taille pour utilisation routière. Le système est le plus installé par la première monte.

Für den Straßenverkehr zugelassene Signaleinrichtung mit kleiner Hupe. Die von den Fahrzeugherstellern meist.



AM80SX The Technological Evolution

Sounds / Suoni / Sonidos / Sons / Klänge 
www.fiammcomponents.com/Horns

ELECTROMAGNETIC HORNS AVVISATORI ELETTROMAGNETICI AVISADORES ELECTROMAGNÉTICOS AVERTISSEURS ÉLECTROMAGNÉTIQUES ELEKTROMAGNETISCHE HUPEN		Voltage Voltaggio Voltaje Tension Spannung	Amp. Draw Assorbimento Amperios Consummation Stromaufnahme	Decibel Liv. sonoro Nivel sonoro Décibels Schallpegel	Frequency Frequenza Frecuencia Fréquence Frequenz	Connectors Connettori Conectores Connecteurs Stecker	M O Q	Packaging u.
		V	A	dB(A) 2m	Hz	See table p. 19		
Steel/ABS 	AM80SX AM80SX - 2T COD. 932306Z + 1 RELAY AM80SX - 2T COD. 932307Z + 1 RELAY	12	9	113	L = 405 H = 495	2T	12 30	I18 L1
	AM80SX/H 12V - 2T COD. 932039Z	12	4,5	110	H = 495	2T	63	I17
	AM80SX/L 12V - 2T COD. 932040Z	12	4,5	110	L = 405	2T	63	I17
	CROSS COUNTRY AM80SX DUAL 2T 12V COD. 932081Z + 1 RELAY	12	9	112	L = 405 H = 495	2T	36	I18
AM80SX/H 2T 12V COD. 932082Z	12	4,5	4,5	H = 495	2T	63	I17	
AM80SX/L 2T 12V COD. 932083Z	12	4,5	109	L = 405	2T	63	I17	

Type approval / Omologazione / Homologación / Homologation / Zulassung
Reg.28/Reg. 10 ECE

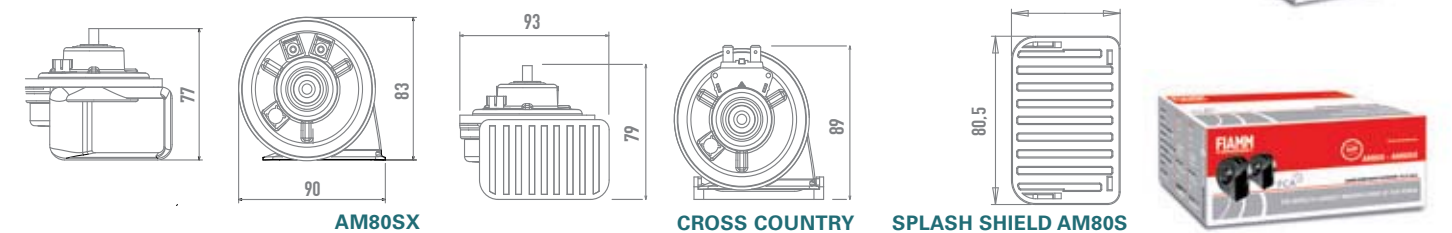

AM80 line

ELECTROMAGNETIC HORNS
AVVISATORI ELETTROMAGNETICI
AVISADORES ELECTROMAGNÉTICOS
AVERTISSEURS ÉLECTROMAGNÉTIQUES
ELEKTROMAGNETISCHE HUPEN





Voltage Voltage Voltaje Tension Spannung	Amp. Draw Assorbimento Amperios Consummation Stromaufnahme	Decibel Liv. sonoro Nivel sonoro Décibels Schallpegel	Frequency Frecuencia Frecuencia Fréquence Frequenz	Connectors Connettori Conectores Connecteurs Stecker	M O Q	Packaging u.
V	A	dB(A) 2m	Hz	See table p.19	u.	

Steel/ABS	KIT	CITROEN / DACIA / PEUGEOT / RENAULT
	AM80SX KIT 2TJS COD. 932326Z + 1 RELAY	12 9 110 L = 405 H = 500 2T JUMPER JPT JUMPER SICMA II 36 I16
	AM80SX/H KIT 2TJS COD. 932324Z	12 4,5 107 H = 500 2T JUMPER JPT JUMPER SICMA II 63 S6
	AM80SX/L KIT 2TJS COD. 932325Z	12 4,5 107 L = 405 2T JUMPER JPT JUMPER SICMA II 63 S6
Steel/ABS	KIT	AUDI / MERCEDES AMG / MERCEDES BENZ / SEAT / SMART / SKODA VOLKSWAGEN
	AM80SX/H KIT 2TV COD. 932327Z	12 4,5 107 H = 500 2T VDA 63 S6
	AM80SX/L KIT 2TJS COD. 932328Z	12 4,5 107 L = 405 2T VDA 63 S6
Steel/ABS	KIT	ALFA ROMEO / ASTON MARTIN / CHEVROLET / FERRARI / FIAT / FORD HOLDEN / JAGUAR / LAND ROVER / LANCIA / MASERATI / NISSAN / OPEL SAAB / VAUXHALL MOTORS / VOLVO
	AM80SX KIT 2TJU COD. 932331Z + 1 RELAY	12 9 110 L = 405 H = 500 2T JUMPER JPT JUMPER USCAR 36 I16
Steel/ABS	KIT	ALFA ROMEO / ASTON MARTIN / FERRARI / FIAT / FORD / JAGUAR LAND ROVER / LANCIA / MASERATI / NISSAN / SAAB / VOLVO
	AM80SX/H KIT 2TJU COD. 932329Z	12 4,5 107 H = 500 2T JPT USCAR 63 S6
	AM80SX/L KIT 2TJU COD. 932330Z	12 4,5 107 L = 405 2T JPT USCAR 63 S6
Steel/ABS	KIT	BMW / MINI
	AM80S/H KIT SP COD. 927384	12 4,5 107 H = 500 ELO STECKER ELO POWER 63 S6
	AM80S/L KIT SP COD. 927385	12 4,5 107 L = 405 ELO STECKER ELO POWER 63 S6
Steel/ABS	KIT	CHEVROLET / HOLDEN / MERCEDES VAN / OPEL / RENAULT VAN VAUXHALL MOTORS / VOLKSWAGEN VAN
	AM80SX/H KIT UP COD. 932332Z	12 4,5 107 H = 500 USCAR PACKARD 63 S6
	AM80SX/L KIT UP COD. 932333Z	12 4,5 107 L = 405 USCAR PACKARD 63 S6

Type approval / Omologazione / Homologación / Homologation / Zulassung
Reg.28/Reg. 10 ECE

ELECTROMAGNETIC HORNS
AVVISATORI ELETTROMAGNETICI
AVISADORES ELECTROMAGNÉTICOS
AVERTISSEURS ÉLECTROMAGNÉTIQUES
ELEKTROMAGNETISCHE HUPEN

Voltage Voltage Voltaje Tension Spannung	Amp. Draw Assorbimento Amperios Consummation Stromaufnahme	Decibel Liv. sonoro Nivel sonoro Décibels Schallpegel	Frequency Frecuencia Frecuencia Fréquence Frequenz	Connectors Connettori Conectores Connecteurs Stecker	M O Q	Packaging u.
V	A	dB(A) 2m	Hz	See table p.19	u.	

Steel/ABS	SUPER	Steel/ABS	LUXE
	AM80S SUPER - 2T COD. 924650 + 1 RELAY		AM80S LUXE - 2T COD. 924648 + 1 RELAY
	12 9 110 L = 405 H = 500 2T 36 I16		12 9 110 L = 405 H = 500 2T 36 I16
Steel/ABS	AM80S	Steel/ABS	VDA
	AM80S-R - 2T COD. 927588 + 1 RELAY		AM80SR/H VDA COD. 924869
	12 9 110 L = 405 H = 500 2T 36 I16		12 4,5 107 H = 500 VDA 63 S6
			AM80SR/L VDA COD. 924870
			12 4,5 107 L = 405 VDA 63 S6

Type approval / Omologazione / Homologación / Homologation / Zulassung
Reg.28/Reg. 10 ECE

ABS	SPLASH SHIELD COD. 920356 KIT OF 4 PCS	AM80SX/AM80S/LLH	18	S4
				

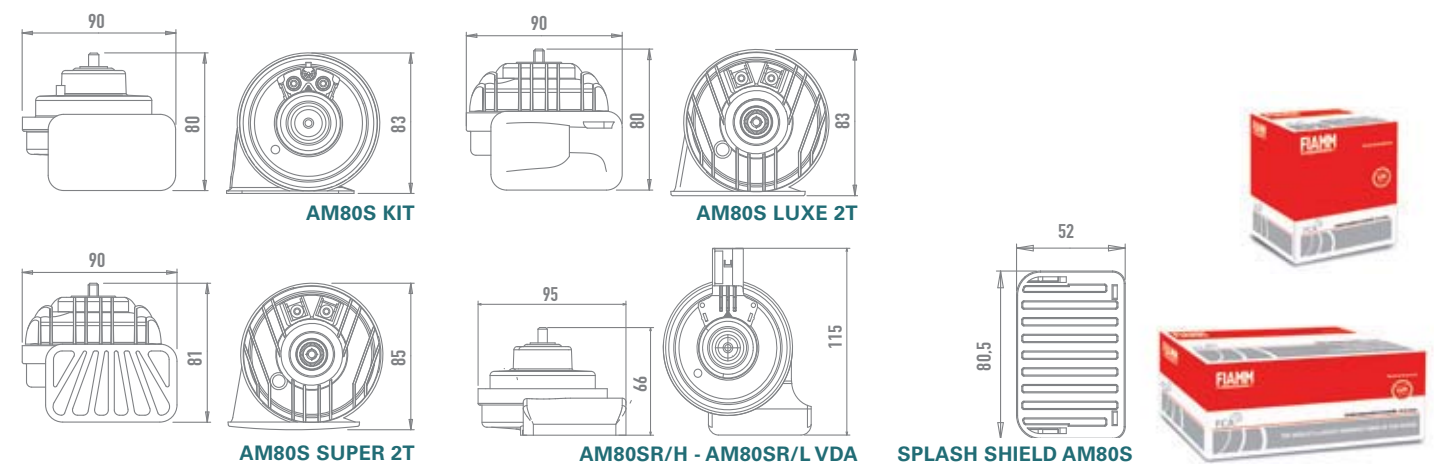

HK line

Approved disc horns, available in the 80 mm version, ideal for applications on motorcycles and small cylinder vehicles, and in the 90 mm version for trucks.





Avvisatori a disco omologati, disponibili nella versione 80 mm, ideale per applicazioni su motocicli e veicoli di piccola cilindrata, e nella versione 90 mm per furgonati.

Bocinas de disco homologadas, disponibles en la versión 80 mm, ideal para aplicaciones en motocicletas y vehículos de pequeña cilindrada, y en la versión 90 mm, para furgonetas.

Avertisseurs à disque homologués, disponibles dans la version 80 mm, pour des applications sur motos et véhicules de petite cylindrée, et dans la version 90 mm pour fourgons.

Zugelassene Teller-Hörner, erhältlich in der 80mm Version, ideal zur Anwendung an Motorrädern und Kleinfahrzeugen und in der 90 mm Version für Lieferwagen.

ELECTROMAGNETIC DISC HORNS DISCHI ELETTROMAGNETICI DISCOS ELECTROMAGNÉTICOS DISQUES ÉLECTROMAGNÉTIQUES ELEKTROMAGNETISCHE TELLERHÖRNER

	Voltage Voltaggio Voltaje Tension Spannung	Amp. Draw Assorbimento Amperios Consummation Stromaufnahme	Decibel Liv. sonoro Nivel sonoro Décibels Schallpegel	Frequency Frequenza Frecuencia Fréquence Frequenz	M O Q	Packaging
	V	A	dB(A) 2m	Hz	u.	
Steel/Aluminium 	HK8 					
HK8 - 2T COD. 930067 + 1 RELAY	12	8	113	L = 350 H = 420	12	I14
HK8/H - 2T COD. 930068	12	4	110	H = 420	18	I12
HK8/L - 2T COD. 930069	12	4	110	L = 350	18	I12
Steel 	HK9 					
HK9 - 2T COD. 920994 + 1 RELAY	12	6	113	L = 340 H = 425	12	I14
HK9/H - 2T COD. 920995	12	3	110	H = 425	18	I13
HK9/L - 2T COD. 920996	12	3	110	L = 340	18	I13
						
HK9 - 2T COD. 920368 + 1 RELAY	24	3	113	L = 340 H = 425	12	I14
HK9/H - 2T COD. 920369	24	1,5	110	H = 425	18	I13
HK9/L - 2T COD. 920370	24	1,5	110	L = 340	18	I13

Type approval / Omologazione / Homologación / Homologation / Zulassung
Reg.28/Reg. 10 ECE

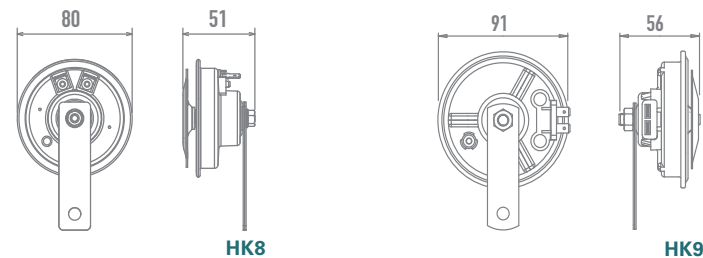

TR99 line

A full range of approved road emergency horns for trucks that can also be used as industrial vehicle warning signals.







Una gamma completa di avvisatori stradali omologati per camion utilizzabili anche come segnalatori per mezzi industriali.

Una gama completa de bocinas de carretera homologadas para camiones, que se pueden utilizar también como señalizadores para vehículos industriales.

Une gamme complète d'avertisseurs routiers homologués pour camions, utilisables aussi comme avertisseurs pour moyens industriels.

Eine komplette Produktreihe mit für den Straßenverkehr zugelassenen Hupen für LKWs, die auch für Industriefahrzeuge geeignet sind.

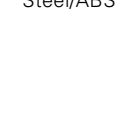
ELECTROMAGNETIC HORNS AVVISATORI ELETTROMAGNETICI AVISADORES ELECTROMAGNÉTICOS AVERTISSEURS ÉLECTROMAGNÉTIQUES ELEKTROMAGNETISCHE HUPEN

	Voltage Voltaggio Voltaje Tension Spannung	Amp. Draw Assorbimento Amperios Consummation Stromaufnahme	Decibel Liv. sonoro Nivel sonoro Décibels Schallpegel	Frequency Frequenza Frecuencia Fréquence Frequenz	M O Q	Packaging
	V	A	dB(A) 2m	Hz	u.	
Steel/ABS 	TR99 2T 					
TR99 - 2T COD. 922010 + 1 RELAY	24	5	112	L = 420 H = 500	12	G1
TR99/L+L - 2T COD. 922012 + 1 RELAY	24	5	112	L = 420	12	G1
Steel/ABS 	TR99 2T 					
TR99/H 24V - 2T COD. 922020	24	2,5	109	H = 500	9	I6
TR99/L 24V - 2T COD. 922021	24	2,5	109	L = 420	9	I6
Steel/ABS 	TR99 JPT 					
TR99/L+L - JPT COD. 922018 + 1 RELAY	24	65	112	L = 420	12	G1

Type approval / Omologazione / Homologación / Homologation / Zulassung
Reg.28/Reg. 10 ECE

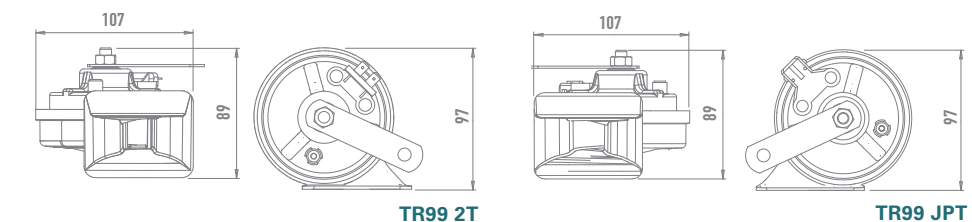



JERICHO line / FA 260 line

Pneumatic horns that operate with on-board air. Bocinas neumáticas, que funcionan con sistema de aire de abordo.

Avvisatori pneumatici, funzionanti con aria di bordo. Avertisseurs pneumatiques, qui fonctionnent avec l'air interne.

Pneumatische Hupen, die mit Fahrzeugdruckluft funktionieren.

PNEUMATIC HORNS AVVISATORI PNEUMATICI AVISADORES NEUMÁTICOS AVERTISSEURS PNEUMATIQUES PNEUMATISCHE HUPEN		Air consumption Consumo d'aria Consumo de aire Consommation d'air Luftverbrauch	Pressure Pressione Presión Pression Betriebsdruck	Decibel Liv. sonoro Nivel sonoro Décibels Schallpegel	Frequency Frequenza Frecuencia Fréquence Frequenz	M O Q	Packaging
		l/sec	kPa	dB(A) 2m	Hz	u.	
ABS  24 V 0,8 A	JERICHO AIR COMPACT DIN CONNECTOR COD. 928028	0,4	300 1000	118	400	13	R
	24V HDSCS CONNECTOR COD. 928026	0,4	300 1000	118	400	13	R
<i>Volvo and Renault Truck since 2013</i>							

	FA 260	7	500 1000	117	260	6	F17
	FA 260 COD. 921130						

Type approval / Omologazione / Homologación / Homologation / Zulassung
Reg.28/Reg. 10 ECE

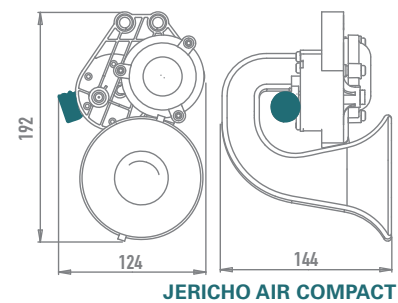

JERICHO AIR COMPACT

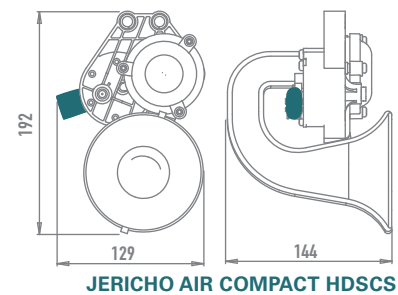

JERICHO AIR COMPACT HDSCS

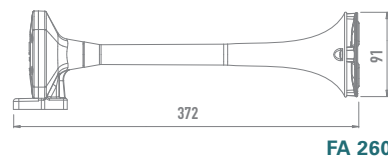

FA 260



TIR line / FULTONE line / TC2 line

PNEUMATIC HORNS AVVISATORI PNEUMATICI AVISADORES NEUMÁTICOS AVERTISSEURS PNEUMATIQUES PNEUMATISCHE HUPEN		Air consumption Consumo d'aria Consumo de aire Consommation d'air Luftverbrauch	Pressure Pressione Presión Pression Betriebsdruck	Decibel Liv. sonoro Nivel sonoro Décibels Schallpegel	Frequency Frequenza Frecuencia Fréquence Frequenz	M O Q	Packaging
		l/sec	kPa	dB(A) 2m	Hz	u.	

Inox Steel 	TIR TA150 COD. 920613	5,5	600 1200	118	150	9	M
	TA180 COD. 920614	5,5	600 1200	118	180	9	M
Standard application MAN / MERCEDES / HYUNDAI							
Inox Steel 	TIR SPOILER TIR COD. 920326 KIT OF 2 PCS	-	-	-	-	9	I5
Inox Steel 	FULTONE FULTONE T COD. 920308	0,9	500 1200	117	L = 260 H = 300	6	F4
	Standard application IVECO						
Chromated Steel 	FULTONE SPOILER FULTONE T COD. 920322 KIT OF 2 PCS	-	-	-	-	9	I5
ABS 	TC2 TC/2 PV COD. 920157	0,9	500 1200	117	L = 392 H = 415	6	F5
	TC/2 PV WITH BRACKET COD. 921126	0,9	500 1200	117	L = 392 H = 415	6	F5

Type approval / Omologazione / Homologación / Homologation / Zulassung
Reg.28/Reg. 10 ECE

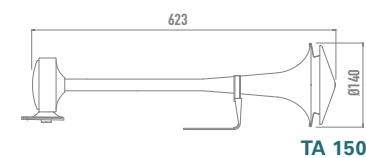

TA 150

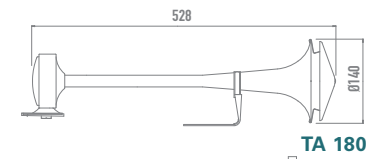

TA 180

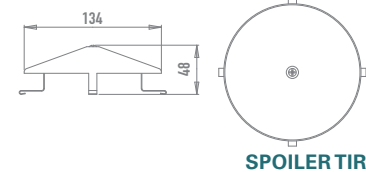

SPOILER TIR

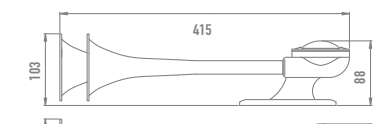

FULTONE

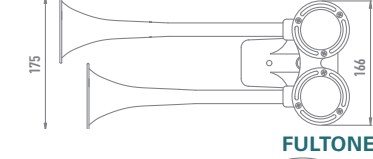

SPOILER FULTONE

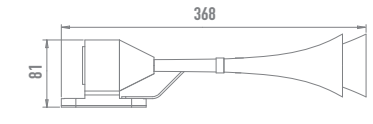

TC2

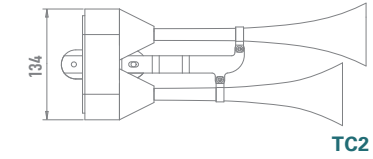

M4 line / MT line / Ultimate Blast

Electropneumatic emergency horns with a clean and powerful sound, equipped with a new and easy installation compressor.

Avvisatori elettropneumatici dal suono potente e pulito, dotati di compressore di nuova generazione di semplice installazione.

Bocinas electroneumáticas con sonido limpio y potente, equipadas con un compresor de nueva generación de fácil instalación.

Avertisseurs électropneumatiques, son puissant et net, pourvus d'un compresseur de nouvelle génération et simple à installer.



Elektropneumatische Hupen mit starkem und sauberem Klang, sie sind mit einem leicht installierbaren Verdichter der neuen Generation ausgestattet.

ELECTROPNEUMATIC HORNS AVVISATORI ELETTROPNEUMATICI AVISADORES ELECTROMAGNÉTICOS AVERTISSEURS ÉLECTROPNEUMATIQUES ELEKTROPNEUMATISCHE HUPEN

	Voltage Voltaggio Voltaje Tension Spannung	Amp. Draw Assorbimento Amperios Consummation Stromaufnahme	Decibel Liv. sonoro Nivel sonoro Décibels Schallpegel	Frequency Frequenza Frecuencia Fréquence Frequenz	H	M	Packaging
	V	A	dB(A) 2m	Hz	mm	u.	
ABS/Steel/Aluminium							
							
ULTIMATE BLAST COD. 921939	12	19	115	L = 530 H = 660	-	12	C4
ULTIMATE BLAST COD. 920621	24	8	115	L = 530 H = 660	-	12	C4
Steel/Aluminium							
							
M4/TA2 COD. 921981 PLASTIC	12	17	116	L = 655 H = 828	203 147	10	B3
M4/TA SPORT COD. 921984 PLASTIC	12	17	116	L = 655 H = 788	193 152	10	B3
Steel/Aluminium							
							
M4/TA2 COD. 921982 PLASTIC	24	8	116	L = 655 H = 828	203 147	10	B3
M4/TA-BLU COD. 921987 PLASTIC	24	8	116	L = 622 H = 788	212 154	10	B3
M4/TA-BLU COD. 921986 PLASTIC	12	17	116	L = 622 H = 788	212 152	10	B3
M4/TA2-M COD. 921985 METAL	12	17	116	L = 622 H = 788	212 152	10	B3

Type approval / Omologazione / Homologación / Homologation / Zulassung
Reg.28/Reg. 10 ECE

ELECTROPNEUMATIC HORNS AVVISATORI ELETTROPNEUMATICI AVISADORES ELECTROMAGNÉTICOS AVERTISSEURS ÉLECTROPNEUMATIQUES ELEKTROPNEUMATISCHE HUPEN

	Voltage Voltaggio Voltaje Tension Spannung	Amp. Draw Assorbimento Amperios Consummation Stromaufnahme	Decibel Liv. sonoro Nivel sonoro Décibels Schallpegel	Frequency Frequenza Frecuencia Fréquence Frequenz	H	M	Packaging
	V	A	dB(A) 2m	Hz	mm	u.	
Steel/Aluminium							
							
M4/TA3 COD. 921983 PLASTIC	12	17	116	L = 655 M = 768 H = 828	203 155 147	10	B3
Steel/Aluminium							
							
TRIO COD. 921967 PLASTIC	12	17	116	L = 655 M = 768 H = 828	203 155 147	10	B1
MT/3i COD. 921969 PLASTIC	12	17	116	L = 622 M = 695 H = 788	212 193 152	10	B1
MT/3i Metal COD. 920387 METAL	12	17	116	L = 622 M = 695 H = 788	213 193 152	10	B2
TRIO COD. 921968 PLASTIC	24	8	116	L = 655 M = 768 H = 828	203 155 147	10	B1
Steel/Aluminium							
							
M4/FUL COD. 921990 INOX STEEL	12	17	115	L = 260 H = 300	-	6	F9

Type approval / Omologazione / Homologación / Homologation / Zulassung
Reg.28/Reg. 10 ECE

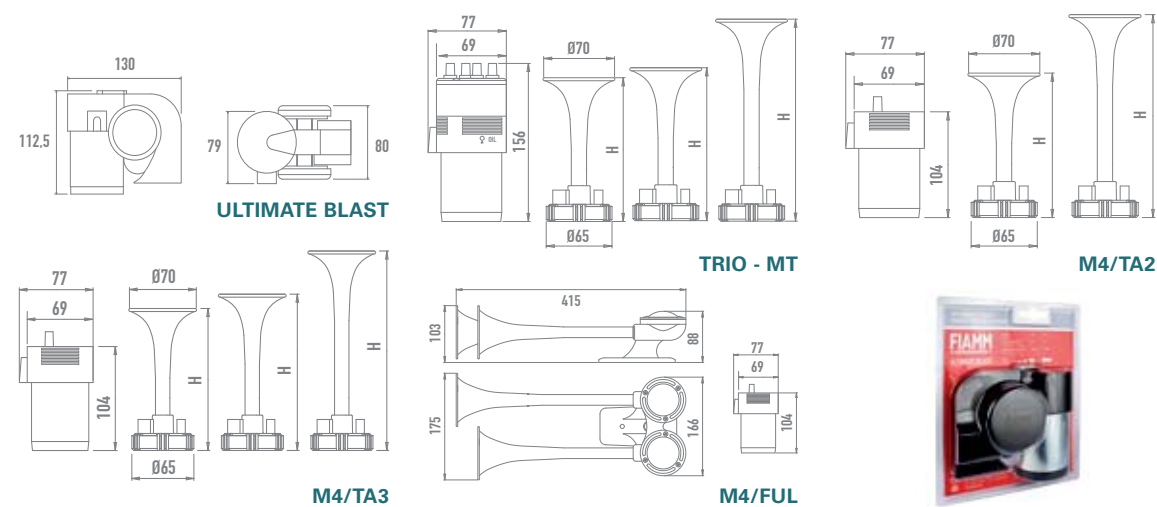

ALA line

Electropneumatic horn ideal for installations on public transport vehicles.

Bocina electroneumática ideal para instalaciones en vehículos de transporte público.

Avvisatore elettropneumatico ideale per installazioni su mezzi di trasporto pubblici di linea.

Avvisateur électropneumatique idéal pour installations sur moyens de transport public urbain.

Elektropneumatische Hupe, ideal für die Installation an öffentlichen Verkehrsmitteln.

ELECTROPNEUMATIC HORNS AVVISATORI ELETTROPNEUMATICI AVISADORES ELECTROMAGNÉTICOS AVERTISSEURS ÉLECTROPNEUMATIQUES ELEKTROPNEUMATISCHE HUPEN

Voltage Voltaggio Voltaje Tension Spannung	Amp. Draw Assorbimento Amperios Consummation Stromaufnahme	Decibel Liv. sonoro Nivel sonoro Décibels Schallpegel	Frequency Frequenza Frecuencia Fréquence Frequenz	M O Q	Packaging
V	A	dB(A) 2m	Hz	u.	
12	17	116	L = 390 H = 490	8	H
24	8	116	L = 390 H = 490	8	H
-	-	116	L = 390 H = 490	8	H3

Type approval / Omologazione / Homologación / Homologation / Zulassung
Reg.28/Reg. 10 ECE

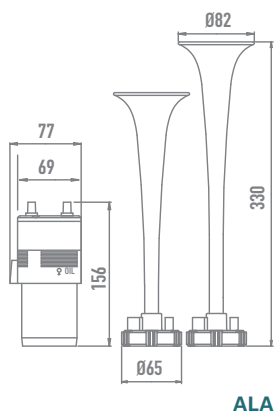

LLH line

LLH, is an electronic snail horn engineered by FIAMM. This horn can be installed in every car model thanks to its compact size due to internal electronics assembly and it ensures a duration of more than 2 million cycles.

LLH, es una bocina electrónica de caracol diseñada por FIAMM. Esta bocina se puede instalar en cualquier modelo de coche gracias a sus dimensiones compactas debido al montaje interior de la electrónica.

LLH, è un avvisatore elettronico a chiocciola progettato da FIAMM. Questo avvisatore può essere installato in qualsiasi modello di auto grazie alle sue dimensioni compatte dovute all'assemblaggio interno dell'elettronica.

LLH, est un avertisseur électronique conçu par FIAMM. Cet avertisseur peut être installé dans tous les modèles de voiture grâce à ses dimensions compactes dues à l'assemblage interne de l'électronique.

LLH, ist eine von FIAMM entwickelte schneckenförmige Hupe. Diese Hupe kann dank seiner kompakten Abmessungen in jedem Auto durch interne Elektronik installiert werden.

ELECTRONIC HORNS AVVISATORI ELETTRONICI AVISADORES ELECTRÓNICOS AVERTISSEURS ÉLECTRONIQUES ELEKTRONISCHE HUPEN

Voltage Voltaggio Voltaje Tension Spannung	Amp. Draw Assorbimento Amperios Consummation Stromaufnahme	Decibel Liv. sonoro Nivel sonoro Décibels Schallpegel	Frequency Frequenza Frecuencia Fréquence Frequenz	Connectors Connettori Conectores Connecteurs Stecker	M O Q	Packaging
V	A	dB(A) 2m	Hz	See table p. xx	u.	
12	9	110	L = 405 H = 500	2T	12	I14
12	4,5	107	H = 500	2T	18	I12
12	4,5	107	L = 405	2T	18	I12



Type approval / Omologazione / Homologación / Homologation / Zulassung
Reg.28/Reg. 10 ECE

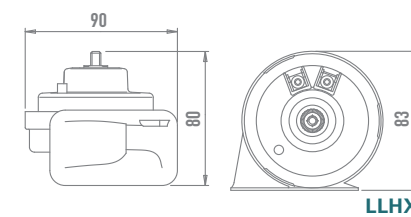

BA line / BK line

ELECTROPNEUMATIC HORNS
AVVISATORI ELETTROPNEUMATICI
AVISADORES ELECTROMAGNÉTICOS
AVERTISSEURS ÉLECTROPNEUMATIQUES
ELEKTROPNEUMATISCHE HUPEN

		Voltage Voltaggio Voltaje Tension Spannung	Amp. Draw Assorbimento Amperios Consummation Stromaufnahme	Decibel Liv. sonoro Nivel sonoro Décibels Schallpegel	Frequency Frequenza Frecuencia Fréquence Frequenz	M O Q	Packaging
		V	A	dB(A) 2m	Hz	u.	
ABS 	BA 						
	BA87 COD. 923152 TYPE C ALARM	24 12	0,5 1	97	1500	18	12
	BA107 COD. 923158 TYPE B ALARM	24 12	0,5 1	107	1400	18	12
Nylon 	BA 						
	BA87 12-80V COD. 923163 TYPE C ALARM	12 80	0,3	97	1270	18	G2
ABS 	BA 						
	BA112 COD. 923159 TYPE A ALARM	24 12	0,5 1	112	1400	9	13
	BA87-112 ADAPTIVE COD. 923160 TYPE A-D ALARM	24 12	0,5 1	87 112 adaptive	1400	9	13
Plastic 	BA 						
	MINI ALARM 97 COD. 923161	12	0,7	97	1700	18	17
Steel/ABS 	BK 						
	BK9 HEAVY DUTY - 2T COD. 923009	24 12	0,7 1,4	94	780	18	11

Type approval / Omologazione / Homologación / Homologation / Zulassung
Reg.28/Reg. 10 ECE

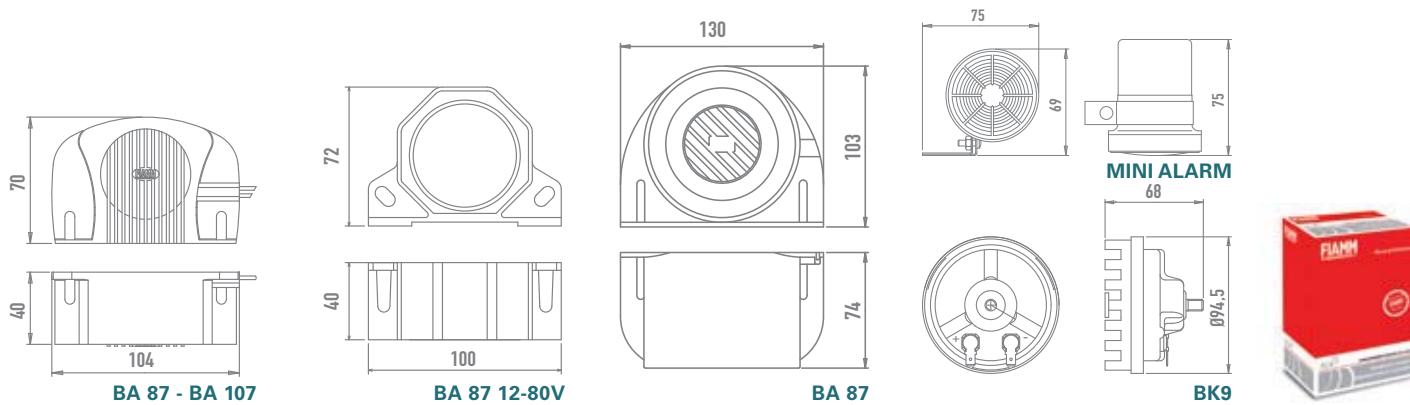

Industrial & Heavy Duty



Electromagnetic
& Electronics Horns
Air Horns
Back-up Alarms

FIAMM



HK line

Approved disc horns, available in the 80 mm version, ideal for applications on motorcycles and small cylinder vehicles, and in the 90 mm version for trucks.

Avvisatori a disco omologati, disponibili nella versione 80 mm, ideale per applicazioni su motocicli e veicoli di piccola cilindrata, e nella versione 90 mm per furgonati.

Bocinas de disco homologadas, disponibles en la versión 80 mm, ideal para aplicaciones en motocicletas y vehículos de pequeña cilindrada, y en la versión 90 mm, para furgonetas.

Avertisseurs à disque homologués, disponibles dans la version 80 mm, pour des applications sur motos et véhicules de petite cylindrée, et dans la version 90 mm pour fourgons.

Zugelassene Teller-Hörner, erhältlich in der 80mm Version, ideal zur Anwendung an Motorrädern und Kleinfahrzeugen und in der 90 mm Version für Lieferwagen.

ELECTROMAGNETIC DISC HORNS
DISCHI ELETTROMAGNETICI
DISCOS ELECTROMAGNÉTICOS
DISQUES ÉLECTROMAGNÉTIQUES
ELEKTROMAGNETISCHE TELLERHÖRNER

Voltage Voltaggio Voltaje Tension Spannung	Amp. Draw Assorbimento Amperios Consummation Stromaufnahme	Decibel Liv. sonoro Nivel sonoro Décibels Schallpegel	Frequency Frequenza Frecuencia Fréquence Frequenz	M O Q	Packaging
V	A	dB(A) 2m	Hz	u.	

Material	Model	Voltage	Amp. Draw	Decibel	Frequency	M	Packaging
Steel/Aluminium	HK8/H - 2T COD. 930068	12	4	110	H = 420	18	112
	HK8/L - 2T COD. 930069	12	4	110	L = 350	18	112
Steel	HK9/H - 2T COD. 920995	12	3	110	H = 425	18	113
	HK9/L - 2T COD. 920996	12	3	110	L = 340	18	113
	HK9/H - 2T COD. 920369	24	1,5	110	H = 425	18	113
	HK9/L - 2T COD. 920370	24	1,5	110	L = 340	18	113

Type approval / Omologazione / Homologación / Homologation / Zulassung
Reg.28/Reg. 10 ECE

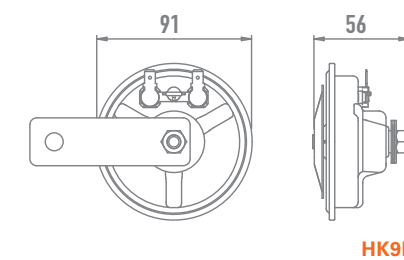
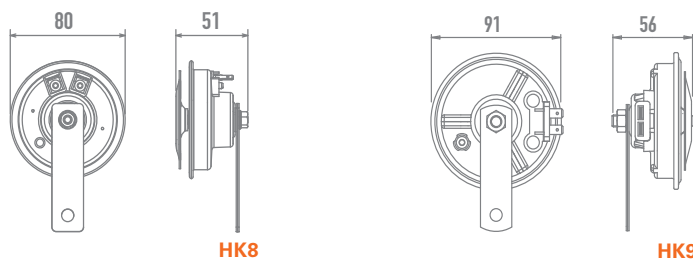

500.000
cycles

HK9E line

ELECTRONIC LONG LIFE HORN
500.000 cycles

Electronic disc horn for industrial and military applications, available in multivoltage 24-48V.

Avvisatore elettronico a disco per applicazioni industriali e militari, disponibile in multitemensione 24-48V.

Bocina electrónica de disco para aplicaciones industriales y militares, disponible en multitemensión 24-48V.

Avertisseur électronique à disque pour applications industrielles et militaires, disponible avec tensions multiples 24-48 V.

Elektronisches Teller-Horn für industrielle und militärische Anwendungen, erhältlich in Multitemperatur 24-48V.

ELECTRONIC DISC HORNS
AVVISATORE ELETTRONICO A DISCO
BOCINA ELECTRÓNICA DE DISCO
AVERTISSEUR ÉLECTRONIQUE À DISQUE
ELEKTRONISCHES TELLERHÖRNER

Voltage Voltaggio Voltaje Tension Spannung	Amp. Draw Assorbimento Amperios Consummation Stromaufnahme	Decibel Liv. sonoro Nivel sonoro Décibels Schallpegel	Frequency Frequenza Frecuencia Fréquence Frequenz	M O Q	Packaging		
V	A	dB(A) 2m	Hz	u.			
Steel/ABS	HK9E						
	HK9/E - 2T COD. 985902	48 24	0,4 0,8	110	430	18	11

Type approval / Omologazione / Homologación / Homologation / Zulassung
Reg.28/Reg. 10 ECE

100.000 cycles **AM80 line**

Compact emergency horn approved for road use. The most commonly installed by car manufacturers.

Avvisatore omologato a cornetto di ridotte dimensioni per uso stradale. Il più installato dai produttori di autoveicoli.

Bocina de caracol homologada, de dimensiones compactas, para el uso por carretera. La bocina más instalada por los fabricantes de automóviles.

Avertisseur homologué, de petite taille pour utilisation routière. Le système est le plus installé par la première monte.

Für den Straßenverkehr zugelassene Signaleinrichtung mit kleiner Hupe. Die von den Fahrzeugherstellern meist.

ELECTROMAGNETIC HORNS AVVISATORI ELETTROMAGNETICI AVISADORES ELECTROMAGNÉTICOS AVERTISSEURS ÉLECTROMAGNÉTIQUES ELEKTROMAGNETISCHE HUPEN		Voltage Voltaggio Voltaje Tension Spannung	Amp. Draw Assorbimento Amperios Consummation Stromaufnahme	Decibel Liv. sonoro Nivel sonoro Décibels Schallpegel	Frequency Frequenza Frecuencia Fréquence Frequenz	Connectors Connettori Conectores Connecteurs Stecker	M O Q	Packaging
		V	A	dB(A) 2m	Hz	See table p. 19	u.	
	AM80SX							
	AM80SX/H 12V - 2T COD. 932039Z	12	4,5	110	H = 495	2T	63	117
	AM80SX/L 12V - 2T COD. 932040Z	12	4,5	110	L = 405	2T	63	117

Type approval / Omologazione / Homologación / Homologation / Zulassung
Reg.28/Reg. 10 ECE

2.000.000 cycles **LLH line**

LLH is an electronic snail horn engineered by FIAMM. This horn can be installed in every car model thanks to its compact size due to internal electronics assembly and it ensures a duration of more than 2 million cycles.

LLH è un avvisatore elettronico a chiocciola progettato da FIAMM. Questo avvisatore può essere installato in qualsiasi modello di auto grazie alle sue dimensioni compatte dovute all'assemblaggio interno dell'elettronica.

LLH es una bocina electrónica de caracol diseñada por FIAMM. Esta bocina se puede instalar en cualquier modelo de coche gracias a sus dimensiones compactas debido al montaje interior de la electrónica.

LLH est un avertisseur électronique conçu par FIAMM. Cet avertisseur peut être installé dans tous les modèles de voiture grâce à ses dimensions compactes dues à l'assemblage interne de l'électronique.

LLH ist eine von FIAMM entwickelte schneckenförmige Hupe. Diese Hupe kann dank seiner kompakten Abmessungen in jedem Auto durch interne Elektronik installiert werden.

ELECTRONIC HORNS AVVISATORI ELETTRONICI AVISADORES ELECTRÓNICOS AVERTISSEURS ÉLECTRONIQUES ELEKTRONISCHE HUPEN		Voltage Voltaggio Voltaje Tension Spannung	Amp. Draw Assorbimento Amperios Consummation Stromaufnahme	Decibel Liv. sonoro Nivel sonoro Décibels Schallpegel	Frequency Frequenza Frecuencia Fréquence Frequenz	Connectors Connettori Conectores Connecteurs Stecker	M O Q	Packaging
		V	A	dB(A) 2m	Hz	See table p. xx	u.	
	LLH							
	LLH/H - 2T COD. 925049	12	4,5	107	H = 500	2T	18	112
	LLH/L - 2T COD. 925048	12	4,5	107	L = 405	2T	18	112

Type approval / Omologazione / Homologación / Homologation / Zulassung
Reg.28/Reg. 10 ECE

TR99 line

A full range of approved road emergency horns for trucks that can also be used as industrial vehicle warning signals.

Una gamma completa di avvisatori stradali omologati per camion utilizzabili anche come segnalatori per mezzi industriali.

Una gama completa de bocinas de carretera homologadas para camiones, que se pueden utilizar también como señalizadores para vehículos industriales.

Une gamme complète d'avertisseurs routiers homologués pour camions, utilisables aussi comme avertisseurs pour moyens industriels.

Eine komplette Produktreihe mit für den Straßenverkehr zugelassenen Hupen für LKWs, die auch für Industriefahrzeuge geeignet sind.

ELECTROMAGNETIC HORNS AVVISATORI ELETTROMAGNETICI AVISADORES ELECTROMAGNÉTICOS AVERTISSEURS ÉLECTROMAGNÉTIQUES ELEKTROMAGNETISCHE HUPEN		Voltage Voltaggio Voltaje Tension Spannung	Amp. Draw Assorbimento Amperios Consummation Stromaufnahme	Decibel Liv. sonoro Nivel sonoro Décibels Schallpegel	Frequency Frequenza Frecuencia Fréquence Frequenz	M O Q	Packaging
		V	A	dB(A) 2m	Hz	u.	
	TR99 2T						
	TR99/H 24V - 2T COD. 922020	24	2,5	109	H = 500	9	16
	TR99/L 24V - 2T COD. 922021	24	2,5	109	L = 420	9	16

Type approval / Omologazione / Homologación / Homologation / Zulassung
Reg.28/Reg. 10 ECE

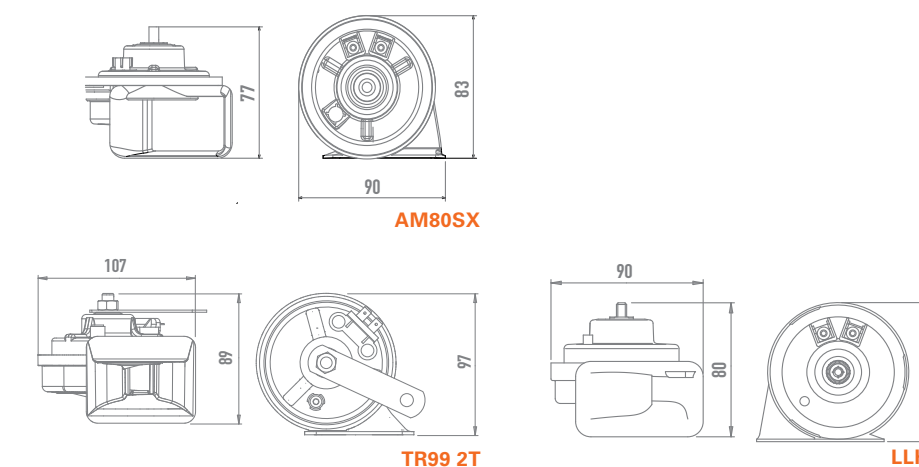

JERICHO line

Pneumatic horns that operate with on-board air.

Bocinas neumáticas, que funcionan con sistema de aire de abordo.

Avvisatori pneumatici, funzionanti con aria di bordo.

Avvisseurs pneumatiques, qui fonctionnent avec l'air interne.

Pneumatische Hupen, die mit Fahrzeugdruckluft funktionieren.

PNEUMATIC HORNS
AVVISATORI PNEUMATICI
AVISADORES NEUMÁTICOS
AVERTISSEURS PNEUMATIQUES
PNEUMATISCHE HUPEN

Air consumption Consumo d'aria Consumo de aire Consommation d'air Luftverbrauch	Pressure Pressione Presión Pression Betriebsdruck	Decibel Liv. sonoro Nivel sonoro Décibels Schallpegel	Frequency Frequenza Frecuencia Fréquence Frequenz	M O Q	Packaging
l/sec	kPa	dB(A) 2m	Hz	u.	

ABS

JERICHO AIR COMPACT



DIN CONNECTOR
COD. 928028

0,4	300 1000	118	400	13	R
-----	-------------	-----	-----	----	---

24 V | 0,8 A

Type approval / Omologazione / Homologación / Homologation / Zulassung
Reg.28/Reg. 10 ECE

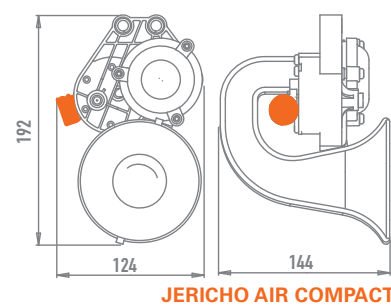

JERICHO AIR COMPACT



TIR line

PNEUMATIC HORNS
AVVISATORI PNEUMATICI
AVISADORES NEUMÁTICOS
AVERTISSEURS PNEUMATIQUES
PNEUMATISCHE HUPEN

Air consumption Consumo d'aria Consumo de aire Consommation d'air Luftverbrauch	Pressure Pressione Presión Pression Betriebsdruck	Decibel Liv. sonoro Nivel sonoro Décibels Schallpegel	Frequency Frequenza Frecuencia Fréquence Frequenz	M O Q	Packaging
l/sec	kPa	dB(A) 2m	Hz	u.	

Inox Steel	TIR	Standard application MAN / MERCEDES / HYUNDAI				
	TA150 COD. 920613	5,5	600 1200	118	150	9 M
	TA180 COD. 920614	5,5	600 1200	118	180	9 M
	SPOILER TIR COD. 920326 KIT OF 2 PCS	-	-	-	-	9 I5
	TA MP COD. 920374	5,5	400 800	128	380	5 F15
	FULTONE T COD. 920308	0,9	500 1200	117	L = 260 H = 300	6 F4

Type approval / Omologazione / Homologación / Homologation / Zulassung
Reg.28/Reg. 10 ECE

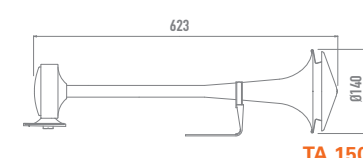

TA 150

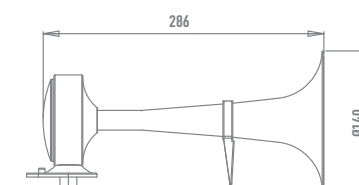

TA MP

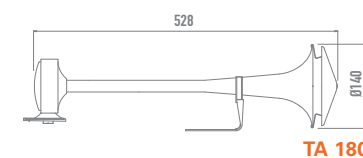

TA 180

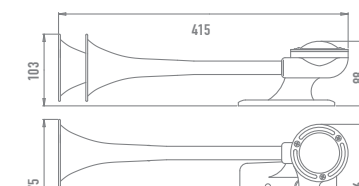

FULTONE

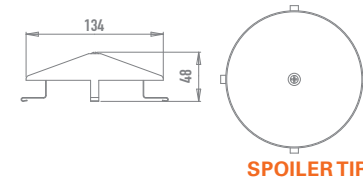

SPOILER TIR



M4 line / MT line / Ultimate Blast

Electropneumatic emergency horns with a clean and powerful sound, equipped with a new and easy installation compressor.

Avvisatori elettropneumatici dal suono potente e pulito, dotati di compressore di nuova generazione di semplice installazione.

Bocinas electroneumáticas con sonido limpio y potente, equipadas con un compresor de nueva generación de fácil instalación.

Avertisseurs électropneumatiques, son puissant et net, pourvus d'un compresseur de nouvelle génération et simple à installer.

Elektropneumatische Hupen mit starkem und sauberem Klang, sie sind mit einem leicht installierbaren Verdichter der neuen Generation ausgestattet.

ELECTROPNEUMATIC HORNS
AVVISATORI ELETTROPNEUMATICI
AVISADORES ELECTROMAGNÉTICOS
AVERTISSEURS ÉLECTROPNEUMATIQUES
ELEKTROPNEUMATISCHE HUPEN

Voltage Voltaggio Voltaje Tension Spannung	Amp. Draw Assorbimento Amperios Consummation Stromaufnahme	Decibel Liv. sonoro Nivel sonoro Décibels Schallpegel	Frequency Frequenza Frecuencia Fréquence Frequenz	H	M	Packaging
V	A	dB(A) 2m	Hz	mm	u.	

Material	Model	Voltage	Amp. Draw	Decibel	Frequency	H	M	Packaging
ABS/Steel/Aluminium	ULTIMATE BLAST COD. 921939	12	19	115	L = 530 H = 660	-	12	C4
	ULTIMATE BLAST COD. 920621	24	8	115	L = 530 H = 660	-	12	C4
Steel/Aluminium	M4/TA2 COD. 921981 PLASTIC	12	17	116	L = 655 H = 828	203	10	B3
	M4/TA SPORT COD. 921984 PLASTIC	12	17	116	L = 655 H = 788	193	10	B3
Steel/Aluminium	M4/TA2 COD. 921982 PLASTIC	24	8	116	L = 655 H = 828	203	10	B3
	M4/TA-BLU COD. 921987 PLASTIC	24	8	116	L = 622 H = 788	212	10	B3
	M4/TA-BLU COD. 921986 PLASTIC	12	17	116	L = 622 H = 788	212	10	B3
	M4/TA2-M COD. 921985 METAL	12	17	116	L = 622 H = 788	212	10	B3

Type approval / Omologazione / Homologación / Homologation / Zulassung
Reg.28/Reg. 10 ECE

ELECTROPNEUMATIC HORNS
AVVISATORI ELETTROPNEUMATICI
AVISADORES ELECTROMAGNÉTICOS
AVERTISSEURS ÉLECTROPNEUMATIQUES
ELEKTROPNEUMATISCHE HUPEN

Steel/Aluminium



M4

M4/TA3
COD. 921983
PLASTIC

Voltage Voltaggio Voltaje Tension Spannung	Amp. Draw Assorbimento Amperios Consummation Stromaufnahme	Decibel Liv. sonoro Nivel sonoro Décibels Schallpegel	Frequency Frequenza Frecuencia Fréquence Frequenz	H	M	Packaging
V	A	dB(A) 2m	Hz	mm	u.	
12	17	116	L = 655 M = 768 H = 828	203	10	B3

Type approval / Omologazione / Homologación / Homologation / Zulassung
Reg.28/Reg. 10 ECE

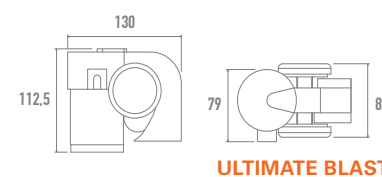

ULTIMATE BLAST

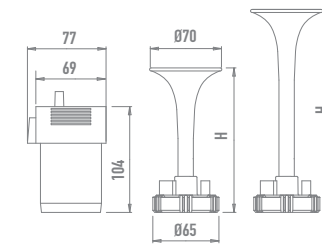

M4/TA2

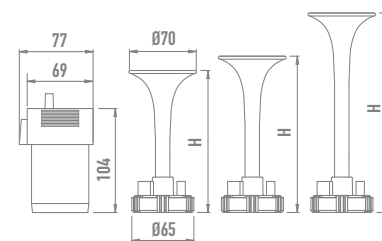

M4/TA3

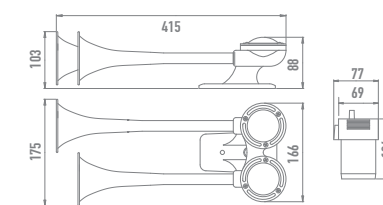

M4/FUL



BA line / BK line

ELECTROPNEUMATIC HORNS
AVVISATORI ELETTROPNEUMATICI
AVISADORES ELECTROMAGNÉTICOS
AVERTISSEURS ÉLECTROPNEUMATIQUES
ELEKTROPNEUMATISCHE HUPEN

		Voltage Voltaggio Voltaje Tension Spannung	Amp. Draw Assorbimento Amperios Consummation Stromaufnahme	Decibel Liv. sonoro Nivel sonoro Décibels Schallpegel	Frequency Frequenza Frecuencia Fréquence Frequenz	M O Q	Packaging
		V	A	dB(A) 2m	Hz	u.	
ABS 	BA 						
	BA87 COD. 923152 TYPE C ALARM	24 12	0,5 1	97	1500	18	12
	BA107 COD. 923158 TYPE B ALARM	24 12	0,5 1	107	1400	18	12
Nylon 	BA 						
	BA87 12-80V COD. 923163 TYPE C ALARM	12 80	0,3	97	1270	18	G2
ABS 	BA 						
	BA112 COD. 923159 TYPE A ALARM	24 12	0,5 1	112	1400	9	13
	BA87-112 ADAPTIVE COD. 923160 TYPE A-D ALARM	24 12	0,5 1	87 112 adaptive	1400	9	13
Plastic 	BA 						
	MINI ALARM 97 COD. 923161	12	0,7	97	1700	18	17
Steel/ABS 	BK 						
	BK9 HEAVY DUTY - 2T COD. 923009	24 12	0,7 1,4	94	780	18	11

Type approval / Omologazione / Homologación / Homologation / Zulassung
Reg.28/Reg. 10 ECE

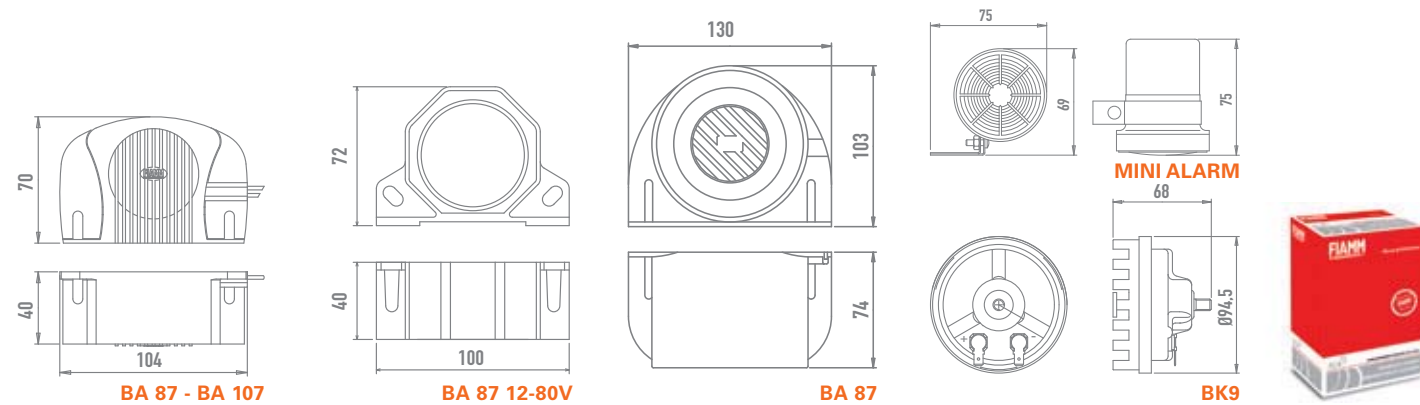

Emergency



Fire Brigades
Police Forces
Ambulances

FIAMM

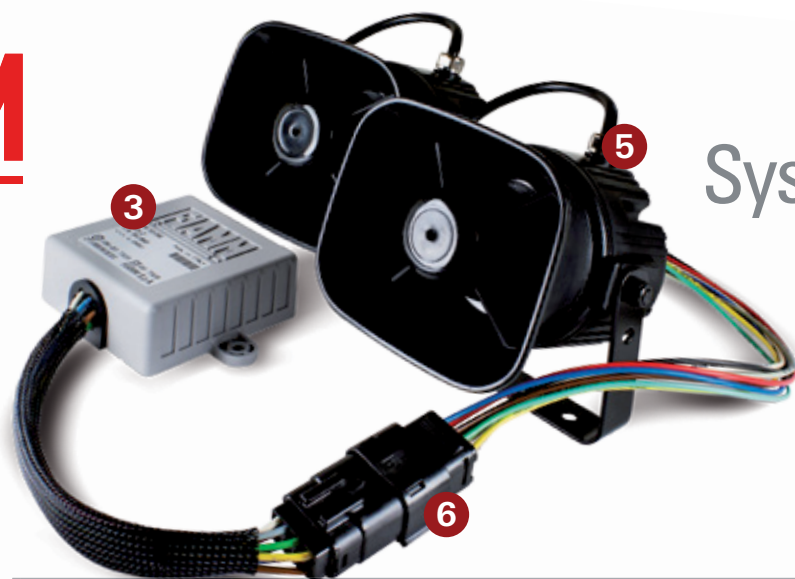

PS10 System Choice

1 >> Choose your country

2 >> Choose your special force:

Fire Brigades
Vigili del fuoco
Bomberos
Sapeurs-Pompiers
Feuerwehr

Ambulance
Ambulanza
Ambulancia
Ambulance
Krankenwagen

Police Forces
Forze dell'ordine
Fuerzas de Policia
Forces de Police
Polizekräfte

3 >> Read the code of your electronic module

4 >> Choose your vehicle type [CAR | VAN | TRUCK]

5 >> Read on the left the code of your loudspeaker

6 >> Complete your system with the mandatory connection cable

	Italy	France	Netherlands	Belgium	United Kingdom	Austria	Germany	Switzerland	Latin America	USA	International
1											
2											
3	PS10 AMB-POMP-I COD. 951001 PS10 AMB-POMP-WY-I COD. 951062 PS10 POL-I COD. 951013	PS10 AMB-F COD. 951004 PS10 UMH-F COD. 951006 PS10 AMB-UMH-F COD. 951069 PS10 GEN-F COD. 951007 PS10 POL-F COD. 951008 PS10 SPO-F COD. 951005 PS10 SPO-F 24V COD. 951023	PS10 EMER-N COD. 951028 PS10 EMER-N SLOW COD. 951089	PS10 EMER-B COD. 951078 PS10 SPO-B NIGHT COD. 951091	PS10 EMER-UK COD. 951035 PS10 EMER-WY-UK COD. 951064	PS10 AMB-A COD. 951046 PS10 FEUER-A COD. 951064	PS10 EMER-D COD. 951060 PS10 USSOUND COD. 951061 PS10 USSOUND-WY COD. 951063				
4	TRUCK 1 module + • 2 loudspeakers	TRUCK 1 module + • 2 loudspeakers	TRUCK 1 module + • 1 loudsp.	TRUCK 1 module + • 2 loudspeakers	TRUCK 1 module + • 2 loudspeakers	TRUCK 1 module + • 2 loudspeakers	TRUCK 1 module + • 2 loudspeakers				
5	CAR VAN TRUCK 1 module + • 1 loudspeaker (Car, Van) • 2 loudspeakers (Car, Van, Truck)	CAR VAN TRUCK 1 module + • 1 loudspeaker (Car, Van) • 2 loudspeakers (Car, Van, Truck)	TRUCK 1 module + • 1 loudsp.	CAR VAN TRUCK 1 module + • 1 loudsp. (Car, Van) • 2 loudsp. (Car, Van, Truck)	CAR VAN TRUCK 1 module + • 1 loudsp. (Car, Van) • 2 loudsp. (Car, Van, Truck)	CAR VAN TRUCK 1 module + • 1 loudsp. (Car, Van) • 2 loudsp. (Car, Van, Truck)	CAR VAN TRUCK 1 module + • 1 loudspeaker (Car, Van) • 2 loudspeakers (Car, Van, Truck)				
6	CAR VAN 1 module + • 1 loudspeaker (Car, Van) • 2 loudspeakers (Car, Van)	CAR VAN 1 module + • 1 loudspeaker (Car, Van) • 2 loudspeakers (Car, Van)	-	CAR VAN 1 module + • 1 loudsp. (Car, Van) • 2 loudsp. (Car, Van)	CAR VAN 1 module + • 1 loudspeaker (Car, Van) • 2 loudspeakers (Car, Van)	CAR VAN 1 module + • 1 loudspeaker (Car, Van) • 2 loudspeakers (Car, Van)	CAR VAN 1 module + • 1 loudspeaker (Car, Van) • 2 loudspeakers (Car, Van)				
	CAR VAN 1 module + • 1 loudspeaker (Car, Van) • 2 loudspeakers (Car, Van)	CAR VAN 1 module + • 1 loudspeaker (Car, Van) • 2 loudspeakers (Car, Van)	-	CAR VAN 1 module + • 1 loudsp. (Car, Van) • 2 loudsp. (Car, Van)	CAR VAN 1 module + • 1 loudspeaker (Car, Van) • 2 loudspeakers (Car, Van)	CAR VAN 1 module + • 1 loudspeaker (Car, Van) • 2 loudspeakers (Car, Van)					
	MOTORBIKE CAR 1 module + • 1 loudspeaker (Motorbike, Car) • 2 loudspeakers (Motorbike, Car)	MOTORBIKE CAR 1 module + • 1 loudspeaker (Motorbike, Car) • 2 loudspeakers (Motorbike, Car)	-	MOTORBIKE CAR 1 module + • 1 loudsp. (Motorbike, Car) • 2 loudsp. (Motorbike, Car)	MOTORBIKE CAR 1 module + • 1 loudsp. (Motorbike, Car) • 2 loudsp. (Motorbike, Car)	MOTORBIKE CAR 1 module + • 1 loudsp. (Motorbike, Car) • 2 loudsp. (Motorbike, Car)					
	CONNECTION CABLE COD. 951057	MANDATORY FOR ALL SYSTEMS NECESSARIO IN TUTTI I SISTEMI DEBERÍA ENTODOS LOS SISTEMAS OBLIGATOIRE POUR TOUS LES SYSTÈMES FÜR ALLE SYSTEME ERFORDERLICH									



MC4 System Choice

1 >> Choose your country

2 >> Choose your special force:



3 >> Read the code of your compressor

4 >> Choose your vehicle type [CAR | VAN | TRUCK]

5 >> Read on the left the code of your trumpets

6 >> Lubricator included in the compressor code

1	Italy			Netherlands		Belgium	United Kingdom		Austria	Germany		Switzerland	Spain	International		✓ = included • = optional		
2																		
3	MC4 FDS 12V COD. 921084	MC4 FVA 12V COD. 921077	MC4 FVA 24V COD. 921078	MC4 FALG 12V COD. 921121	MC4 FALG 24V COD. 921122	MC4 FI 24V COD. 921124	MC4 FI 12V COD. 921123	MC4 FI 24V COD. 921124	MC4 FD 12V COD. 921116	MC4 FA 12V COD. 921118	MC4 FA 24V COD. 921119	MC4 FD 12V COD. 921116	MC4 FD 24V COD. 921117	MC4 FD 12V COD. 921116	MC4 FD 24V COD. 921117	MC4 FI 12V COD. 921123	MC4 FI 24V COD. 921124	SPOLLER COD. 920618
4	TA/2 906-V COD. 920392	CAR VAN 1 compressor + 1 set of trumpets							CAR VAN 1 compressor + 1 set of trumpets			CAR VAN 1 compressor + 1 set of trumpets	TRUCK 1 compressor + 1 set of trumpets	CAR VAN 1 compressor + 1 set of trumpets	TRUCK 1 compressor + 1 set of trumpets	CAR VAN TRUCK 1 compressor + 1 set of trumpets	TRUCK 1 compressor + 1 set of trumpets	✓
	TA/2 906-C COD. 920393	CAR VAN 1 compressor + 1 set of trumpets							CAR VAN 1 compressor + 1 set of trumpets			CAR VAN 1 compressor + 1 set of trumpets	TRUCK 1 compressor + 1 set of trumpets			CAR VAN TRUCK 1 compressor + 1 set of trumpets	TRUCK 1 compressor + 1 set of trumpets	✓
	TA/2 VA-V COD. 920395		CAR VAN 1 compressor + 1 set of trumpets	TRUCK 1 compressor + 1 set of trumpets														✓
	TA/2 GA-V COD. 920615				CAR VAN 1 compressor + 1 set of trumpets	TRUCK 1 compressor + 1 set of trumpets												•
	TA/2 GB-V COD. 920616				CAR VAN 1 compressor + 1 set of trumpets	TRUCK 1 compressor + 1 set of trumpets												•
	TA/2 BL-C COD. 920629						TRUCK 1 compressor + 1 set of trumpets	CAR VAN 1 compressor + 1 set of trumpets	TRUCK 1 compressor + 1 set of trumpets									•
	TA/2 BL-V COD. 920396						TRUCK 1 compressor + 1 set of trumpets	CAR VAN 1 compressor + 1 set of trumpets	TRUCK 1 compressor + 1 set of trumpets									•
	TA/2 DE-B COD. 920397								CAR VAN 1 compressor + 1 set of trumpets	TRUCK 1 compressor + 1 set of trumpets								•
	TA/4 906-C COD. 920394										CAR VAN 1 compressor + 1 set of trumpets	TRUCK 1 compressor + 1 set of trumpets			CAR VAN TRUCK 1 compressor + 1 set of trumpets	TRUCK 1 compressor + 1 set of trumpets	✓	
	TA/2 LE-V COD. 920400												CAR VAN 1 compressor + 1 set of trumpets	TRUCK 1 compressor + 1 set of trumpets				
6	LUBRICATOR COD. 920617	ALWAYS INCLUDED WITH THE COMPRESSOR, IN CASE ALSO AVAILABLE AS A SPARE PART										ALWAYS INCLUDED WITH THE COMPRESSOR, IN CASE ALSO AVAILABLE AS A SPARE PART						

FIAMM



PS20 System Choice

1 >> Choose your country

2 >> Choose your special force:

Fire Brigades
Vigili del fuoco
Bomberos
Sapeurs-Pompiers
Feuerwehr

Ambulance
Ambulanza
Ambulancia
Ambulance
Krankenwagen

Police Forces
Forze dell'ordine
Fuerzas de Policia
Forces de Police
Polizekräfte

3 >> Read the code of your electronic control unit

4 >> Choose your vehicle type [CAR | VAN | TRUCK]

5 >> Read on the left the code of your trumpets

	Italy		Netherlands	Belgium	United Kingdom		Austria			Germany		Switzerland		International		✓ = included • = optional		
									1	2	3	4	5	6	7			
	PS20 - POL - I 12V COD. 951081	PS20 AMB/POMP - I 12V COD. 951082	PS20 AMB/POMP - I 24V COD. 951083	PS20 - HI-LO 12V COD. 951079	PS20 - HI-LO 24V COD. 951080	PS20 - HI-LO 12V COD. 951079	PS20 - HI-LO 24V COD. 951080	PS20 EMER - D 12V COD. 951084	PS20 - FEUER - A 12V COD. 951087	PS20 - FEUER - A 24V COD. 951088	PS20 - FEUER - A 24V COD. 951086	PS20 EMER - D 12V COD. 951084	PS20 EMER - D 24V COD. 951085	PS20 EMER - D 12V COD. 951084	PS20 EMER - D 24V COD. 951085	PS20 - HI-LO 12V COD. 951079	PS20 - HI-LO 24V COD. 951080	SPOILER COD. 920618
TA/2 906-V COD. 920392	CAR VAN 1 electr.unit + 1 set of trumpets							CAR VAN 1 electr.unit + 1 set of trumpets				CAR VAN 1 electr.unit + 1 set of trumpets	TRUCK 1 compressor + 1 set of trumpets	CAR VAN 1 electr.unit + 1 set of trumpets	TRUCK 1 electr.unit + 1 set of trumpets	CAR VAN TRUCK 1 electr.unit + 1 set of trumpets	TRUCK 1 electr.unit + 1 set of trumpets	✓
TA/2 906-C COD. 920393	CAR VAN 1 electr.unit + 1 set of trumpets							CAR VAN 1 electr.unit + 1 set of trumpets				CAR VAN 1 electr.unit + 1 set of trumpets	TRUCK 1 compressor + 1 set of trumpets	CAR VAN 1 electr.unit + 1 set of trumpets	TRUCK 1 electr.unit + 1 set of trumpets	CAR VAN TRUCK 1 electr.unit + 1 set of trumpets	TRUCK 1 electr.unit + 1 set of trumpets	✓
TA/2 VA-V COD. 920395		CAR VAN 1 electr.unit + 1 set of trumpets	TRUCK 1 electr.unit + 1 set of trumpets															✓
TA/2 BL-C COD. 920629					TRUCK 1 electr.unit + 1 set of trumpets	CAR VAN 1 electr.unit + 1 set of trumpets	TRUCK 1 electr.unit + 1 set of trumpets											•
TA/2 BL-V COD. 920396					TRUCK 1 electr.unit + 1 set of trumpets	CAR VAN 1 electr.unit + 1 set of trumpets	TRUCK 1 electr.unit + 1 set of trumpets											•
TA/2 DE-B COD. 920397									CAR VAN 1 electr.unit + 1 set of trumpets	TRUCK 1 electr.unit + 1 set of trumpets	TRUCK 1 electr.unit + 1 set of trumpets							•
TA/4 906-C COD. 920394												CAR VAN 1 electr.unit + 1 set of trumpets	TRUCK 1 compressor + 1 set of trumpets	CAR VAN 1 electr.unit + 1 set of trumpets	TRUCK 1 electr.unit + 1 set of trumpets	CAR VAN TRUCK 1 electr.unit + 1 set of trumpets	TRUCK 1 electr.unit + 1 set of trumpets	✓
TA/4 NL-C+SPOILER COD. 920647																CAR VAN TRUCK 1 electr.unit + 1 set of trumpets		

PS10 System

Electronic priority emergency horn for continuous service, ensuring a powerful, clean sound. Systems equipped with a control unit with degree of protection IP67 and Loudspeaker IP 66. The PS10 system, thanks to its flexibility, complies with national standard requirements and can produce several sounds and is therefore easily customisable.

Avisador prioritario electrónico para servicio continuo que garantiza un sonido potente y limpio. Sistema dotado de unidad de control con grado de protección IP67 y de altavoces IP66. El sistema PS10, gracias a su flexibilidad, cumple con las normas nacionales y puede reproducir tonalidades diferentes, entonces es fácilmente personalizable.

Avvisatore prioritario elettronico per servizio continuo che garantisce un suono potente e pulito. Sistema dotato di centralina con grado di protezione IP67 e di Altoparlanti IP 66. Il sistema PS10, grazie alla sua flessibilità, risponde alle normative nazionali richieste e può produrre più suoni, per cui è facilmente customizzabile.

Avertisseur prioritaire électronique pour service continu qui garantit un son puissant et net. Système pourvu de centrale avec degré de protection IP67 et de haut-parleurs IP 66. Le système PS10, grâce à sa flexibilité, répond aux normes nationales exigées et peut produire plusieurs sons, c'est pourquoi il est facilement adaptable.

Bevorrechtigte elektronische Hupe für den Dauerbetrieb. Sie garantiert einen starken und sauberen Klang. System mit Steuereinheit, Schutzgrad IP67 und Lautsprechern IP66. Das System PS10 entspricht dank seiner Flexibilität den national geforderten Richtlinien und kann mehrere Klänge erzeugen, weshalb es sich leicht der jeweiligen Anwendung anpassen lässt.

INTERNATIONAL Hi-Lo
AMERICAN SOUND Wail /Yelp



ITALY
FRANCE
NETHERLANDS
BELGIUM
UK
AUSTRIA
GERMANY
SWITZERLAND
LATIN AMERICA

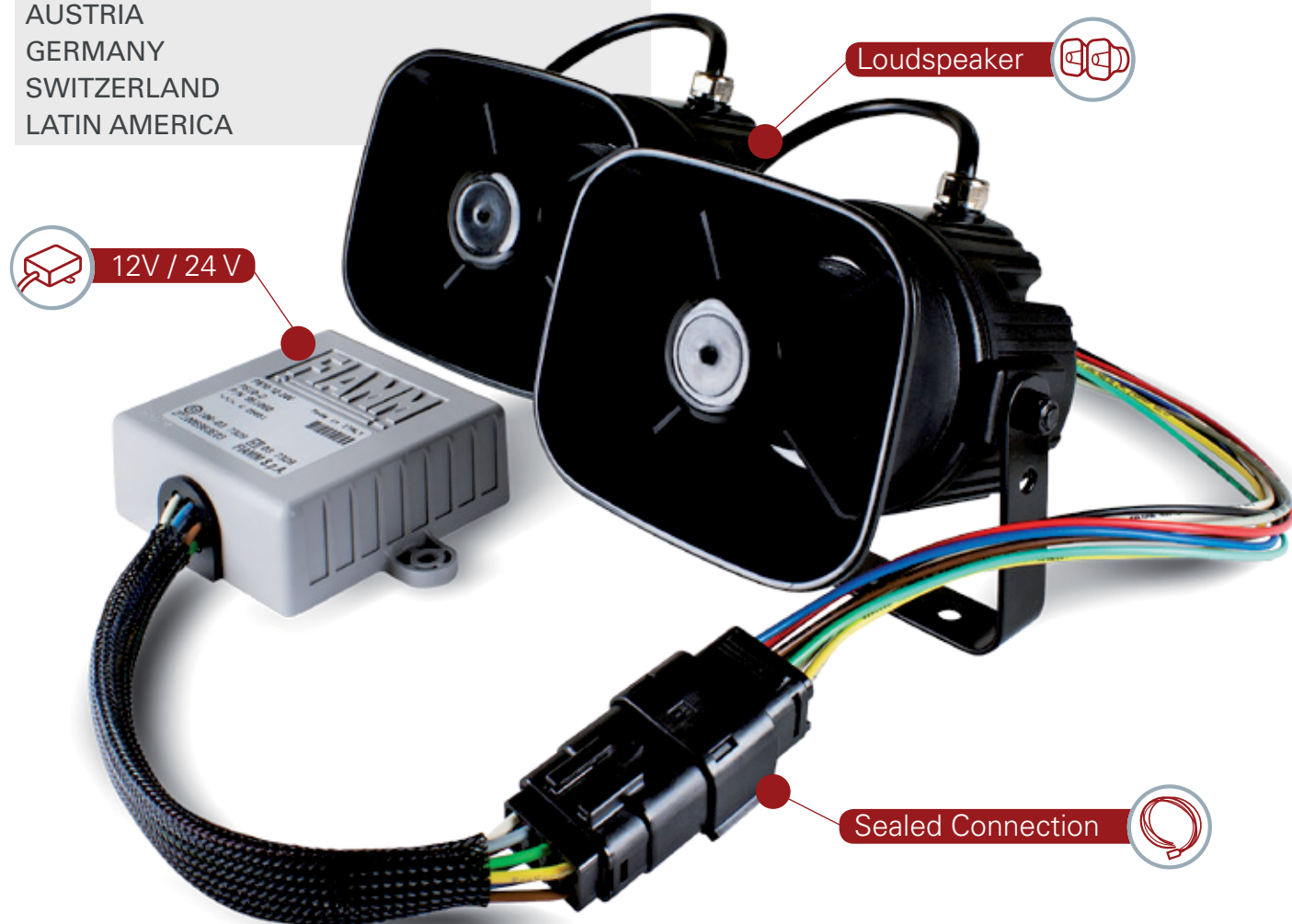

Loudspeaker

Sealed Connection

ELECTRONIC EMERGENCY HORNS AVVISATORI ELETTRONICI DI EMERGENZA AVISADORES ELECTRÓNICOS DE EMERGENCIA AVERTISSEURS ÉLECTRONIQUES ELEKTRONISCHE HUPEN

Flame retardant PBT



PS10
COD. 951001

PS10 - AMB-POMP-I
COD. 951001

PS10 - AMB-POMP-WY-I
COD. 951062

PS10 - POL-I
COD. 951013

PS10 - AMB-F
COD. 951004

PS10 - UMH-F
COD. 951006

PS10 - AMB-UMH-F
COD. 951059

PS10 - GEN-F
COD. 951007

PS10 - POL-F
COD. 951008

PS10 - SPO-F
COD. 951005

PS10 - SPO-F 24V
COD. 951023
SPECIAL FOR 1 LOUDSPEAKER

PS10 - EMER- N
COD. 951028

PS10-EMER-N SLOW
COD. 951089







Voltage Voltage Tension Spannung	Amp. Draw Assorbimento Consummation Stromaufnahme	Frequency Frequenza Fréquence Frequenz	Option	Country	M O Q	Packaging
V	A	Hz				u.
12 24	3,5 1,75	L = 392 H = 660	-	Italy	8	S
12 24	3,5 1,75	L = 392 H = 523	Wail/Yelp	Italy	8	S
12 24	3,5 1,75	L = 466 H = 622	-	Italy	8	S
12 24	3,5 1,75	L = 420 H = 516	-	France	8	S
12 24	3,5 1,75	L = 435 H = 651	Day/Night	France	8	S
12 24	3,5 1,75	-	Ambulance UMH Day/Night	France	8	S
12 24	3,5 1,75	L = 435 H = 732	-	France	8	S
12 24	3,5 1,75	L = 435 H = 580	Day/Night	France	8	S
12 24	3,5 1,75	L = 435 H = 488	-	France	8	S
12 24	1,75	L = 435 H = 488	-	France	8	S
12 24	3,5 1,75	L = 375 H = 500	Fast/Slow	Netherlands	8	S
12 24	3,5 1,75	L = 360 H = 480	Fast/Slow	Netherlands	8	S

Type approval / Omologazione / Homologación / Homologation / Zulassung
Reg. 10 / National homologation if required

Sounds / Suoni / Sonidos / Sons / Klänge
www.fiammcomponents.com/Horns

PS10 System

ELECTRONIC EMERGENCY HORNS
AVVISATORI ELETTRONICI DI EMERGENZA
AVISADORES ELECTRÓNICOS DE EMERGENCIA
AVERTISSEURS ÉLECTRONIQUES
ELEKTRONISCHE HUPEN

	Voltage Voltage Tension Spannung	Amp. Draw Assorbimento Amperios Consummation Stromaufnahme	Frequency Frecuencia Fréquence Frequenz	Option	Country	M O Q	Packaging
	V	A	Hz				u.
Flame retardant PBT							
PS10 							
PS10 - EMER-B COD. 951078	12 24	3,5 1,75	L = 440 H = 495	Day/Night	Belgium	8	S
PS10-SPO-B NIGHT COD. 951091	12 24	3,5 1,75	L = 440 H = 495	-	Belgium	8	S
							
PS10 - EMER-UK COD. 951035	12 24	3,5 1,75	L = 440 H = 495	-	United Kingdom	8	S
PS10 - EMER-WY-UK COD. 951034	12 24	3,5 1,75	L = 440 H = 495	Wail/Yelp	United Kingdom	8	S
							
PS10 - AMB-A COD. 951046	12 24	3,5 1,75	L = 450 H = 600	-	Austria	8	S
PS10 - FEUER-A COD. 951064	12 24	3,5 1,75	L = 392 H = 523	-	Austria	8	S
							
PS10 - EMER-D COD. 951060	12 24	3,5 1,75	L = 430 H = 570	Stadt/Land	Germany Switzerland	8	S
							
PS10 - USSOUND COD. 951061 WAIL/YELP	12 24	3,5 1,75	L = 430 H = 570	-	Latin America	8	S
							
PS10 - USSOUND-WY COD. 951063 HI-LO	12 24	3,5 1,75	L = 560 H = 650	Wail/Yelp	International USA	8	S

Type approval / Omologazione / Homologación / Homologation / Zulassung
Reg. 10 / National homologation if required

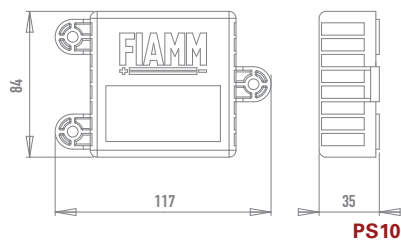

PS10



Loudspeakers

The PS10 system offers 7 different types of loudspeakers to permit the best installation suitable for different needs. There are loudspeakers in ferrite and neodymium, available in various dimensions for internal or external vehicle installation.

Il sistema PS10 dispone di 7 diverse tipologie di altoparlanti per permettere un'installazione adatta alle diverse esigenze. Vi sono altoparlanti in ferrite e in neodimio, disponibili in diverse dimensioni per installazioni interne o esterne al veicolo.



El sistema PS10 dispone de 7 tipos diferentes de altavoces para una instalación apropiada a las diferentes exigencias. Hay altavoces de ferrita y de neodimio, disponibles en diferentes dimensiones para instalaciones internas o externas al vehículo.

Le système PS10 dispose de 7 typologies de haut-parleurs différentes, afin de permettre une installation adaptée aux diverses exigences. Il y a des haut-parleurs en ferrite et en néodyme, disponibles dans différentes dimensions pour des installations internes ou externes au véhicule.

Das System PS10 verfügt über 7 unterschiedliche Lautsprechertypen, um eine den verschiedenen Anforderungen entsprechende Installation zu ermöglichen. Es gibt Lautsprecher aus Ferrit und aus Neodym, die in verschiedenen Größen zur Installation im Innern oder außen am Fahrzeug erhältlich sind.

LOUDSPEAKERS
ALTOPARLANTI
ALTAVOCES
HAUT-PARLEURS
LAUTSPRECHER

FERRITE MAGNET

	Voltage Voltage Tension Spannung	Decibel Liv. sonoro Nivel sonoro Décibels Schallpegel	Nominal power Potenza lavoro Potencia nominal Puissance nominale Betriebleistung	Peak power Potenza di punta Potencia de pico Puissance de crête Maximale Leistung	Impedance Impedenza Impedancia Impédance Inpedanz	M O Q	Packaging
	V	dB(A) 2m	W	W	Ohm	u.	
ABS / Ferrite Magnet							
 LOUDSPEAKER - FB COD. 951051	12 24	115	25	40	4	8	F12
ABS / Ferrite Magnet							
 LOUDSPEAKER - FM COD. 951052	12 24	114	25	40	4	8	G8
 LOUDSPEAKER - FMW COD. 951077 UV PROTECTION	12 24	114	25	40	4	8	G8
ABS / Ferrite Magnet							
 LOUDSPEAKER - FS COD. 951053	12 24	113	25	40	4	8	G8

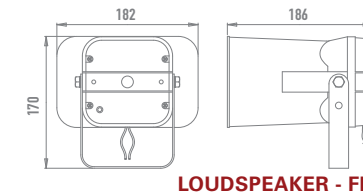

LOUDSPEAKER - FB

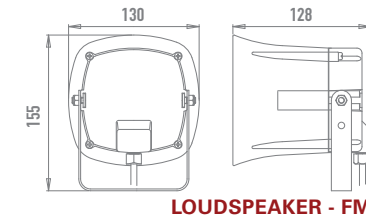

LOUDSPEAKER - FM

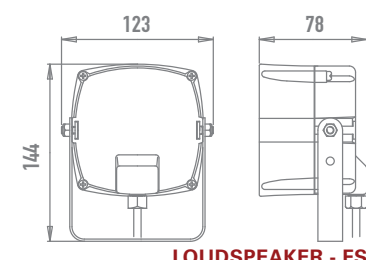

LOUDSPEAKER - FS











Loudspeaker

LOUDSPEAKERS
ALTOPARLANTI
ALTAVOCES
HAUT-PARLEURS
LAUTSPRECHER

Voltage Voltaggio Voltaje Tension Spannung	Decibel Liv. sonoro Nivel sonoro Décibels Schallpegel	Nominal power Potenza lavoro Potencia nominal Puissance nominale Betriebleistung	Peak power Potenza di punta Potencia de pico Puissance de crête Maximale Leistung	Impedance Impedenza Impedancia Impédance Inpedanz	M O Q	Packaging u.
V	dB(A) 2m	W	W	Ohm		

NEODYMIUM MAGNET

 ABS / Neodymium Magnet NB LOUDSPEAKER -NB COD. 951054	 Degree of protection: IP66	12 24	117	50	70	4	8	F12
 ABS / Neodymium Magnet NSC LOUDSPEAKER -NSC COD. 951055	 Degree of protection: IP66	12 24	113	20	30	4	8	G5
 ABS / Neodymium Magnet NS LOUDSPEAKER -NS COD. 951056	 Degree of protection: IP66	12 24	113	20	30	4	4	G9

 CONNECTION CABLE PS10 COD. 951057	 Degree of protection: IP67	4	4	19
--	---	---	---	----

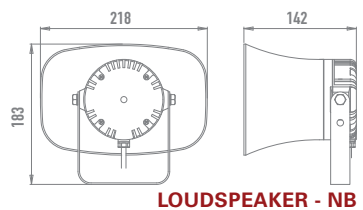

LOUDSPEAKER - NB

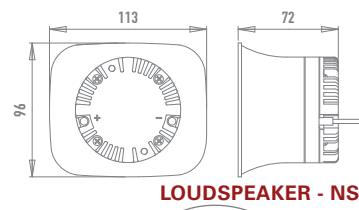

LOUDSPEAKER - NS

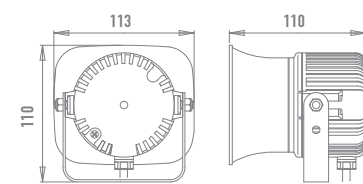

LOUDSPEAKER - NSC

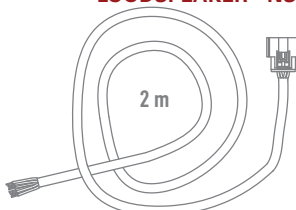

CONNECTION CABLE PS10







For the italian market, special kits to integrate offers

Per il mercato italiano, l'offerta si completa con i kit dedicati

ELECTRONIC EMERGENCY HORNS
 AVVISATORI ELETTRONICI DI EMERGENZA
 AVISADORES ELECTRÓNICOS DE EMERGENCIA
 AVERTISSEURS ÉLECTRONIQUES
 ELEKTRONISCHE HUPEN

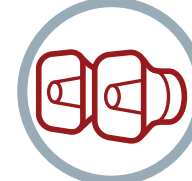
Voltage Voltaggio Voltaje Tension Spannung	Amp. Draw Assorbimento Amperios Consummation Stromaufnahme	Decibel Liv. sonoro Nivel sonoro Décibels Schallpegel	Country	M O Q	Packaging u.
V	A	dB(A) 2m			

 PS10 PS10 - FB-AMB-POMP-I COD. 951009 KIT OF MODULE + 2 FB SPEAKER + CABLE	 PS10 - NB-AMB-POMP-I COD. 951012 KIT OF MODULE + 2 NB SPEAKER + CABLE	 PS10 - FM-AMB-POMP-I COD. 951019 KIT OF MODULE + 2 FM SPEAKER + CABLE	 PS10 - FMW-AMB-I COD. 951022 KIT OF MODULE + 2 FMW SPEAKER + CABLE	 PS10 - FS-AMB-POMP-I COD. 951010 KIT OF MODULE + 2 FS SPEAKER + CABLE	 PS10 - NSC-AMB-POMP-I COD. 951011 KIT OF MODULE + 2 NSC SPEAKER + CABLE	 PS10 - FB-POL-I COD. 951015 KIT OF MODULE + 2 FB SPEAKER + CABLE	 PS10 - NB-POL-I COD. 951018 KIT OF MODULE + 2 NB SPEAKER + CABLE	 PS10 - FM-POL-I COD. 951020 KIT OF MODULE + 2 FM SPEAKER + CABLE	 PS10 - FS-POL-I COD. 951016 KIT OF MODULE + 2 FS SPEAKER + CABLE	 PS10 - NSC-POL-I COD. 951017 KIT OF MODULE + 2 NSC SPEAKER + CABLE																															
12 24	4 2	121 123	Italy	5 5	F6 F11	12 24	4 2	120	Italy	4 4	G6 G6	12 24	4 2	119	Italy	8 8	G7 G7	12 24	4 2	121 123	Italy	5 5	F6 F11	12 24	4 2	120	Italy	4 4	G6 G6	12 24	4 2	119	Italy	8 8	G7 G7	12 24	4 2	119	Italy	8 8	F12 F12

KIT ITALIA

MC4 System

High power, directional Electropneumatic emergency horn systems to be used as primary signals on temporary exit vehicles or as secondary signals to successfully overcome difficult traffic situations or for dangerous crossroads.

Sistema di avvisatore elettropneumatico dal suono potente e direzionale utilizzabile come primo avvisatore in mezzi di uscita temporanea o come avvisatore secondario per superare in sicurezza le situazioni di traffico difficili o per gli incroci pericolosi.

Sistema prioritario electroneumático de sonido potente y direccional para vehículos de salida temporal o utilizable como avisador secundario para superar en seguridad las situaciones de tráfico difíciles o para los cruces más peligrosos.

Système d'avertisseur électropneumatique, son puissant et directionnel utilisable ponctuellement ou comme avertisseur secondaire pour affronter en toute sécurité les situations de circulation difficiles.

Elektropneumatische Signaleinrichtung mit starkem und gerichtetem Klang. Als erste Signaleinrichtung in Fahrzeugen, die zeitweise ausfahren, oder als sekundäre Signaleinrichtung für die sichere Überwindung schwieriger Verkehrssituationen oder gefährlicher Kreuzungen einsetzbar.

INTERNATIONAL Hi-Lo

- ITALY
- NETHERLANDS
- BELGIUM
- UK
- AUSTRIA
- GERMANY
- SWITZERLAND



Sounds / Suoni / Sonidos / Sons / Klänge

www.fiammcomponents.com/Horns

COMPRESSORS COMPRESSORI COMPRESORES COMPRESSEURS GEBLÄSE

Steel/Aluminium



	Voltage Voltaggio Voltaje Tension Spannung	Amp. Draw Assorbimento Amperios Consummation Stromaufnahme	Country	Type approval	M O Q	Packaging
MC4 FDS 12V + LUBRICATOR COD. 921084	12	17	Italy	National/ Reg.10	4	I11
MC4 FVA 12V + LUBRICATOR COD. 921077	12	17	Italy	National/ Reg.10	4	I11
MC4 FVA 24V + LUBRICATOR COD. 921078	24	8	Italy	National/ Reg.10	4	I11
MC4 FALG 12V + LUBRICATOR COD. 921121	12	17	Netherlands	Reg. 10 ECE	4	I11
MC4 FALG 24V + LUBRICATOR COD. 921122	24	8	Netherlands	Reg. 10 ECE	4	I11
MC4 FI 24V + LUBRICATOR COD. 921124	24	8	Belgium, UK International	Reg. 10 ECE	4	I11
MC4 FI 12V + LUBRICATOR COD. 921123	12	17	UK International	Reg. 10 ECE	4	I11
MC4 FD 12V + LUBRICATOR COD. 921116	12	17	Austria	Reg. 10 ECE	4	I11
MC4 FA 12V + LUBRICATOR COD. 921118	12	17	Austria	Reg. 10 ECE	4	I11
MC4 FA 24V + LUBRICATOR COD. 921119	24	8	Austria	Reg. 10 ECE	4	I11
MC4 FD 12V + LUBRICATOR COD. 921116	12	17	Germany Switzerland	National/ Reg.10	4	I11
MC4 FD 24V + LUBRICATOR COD. 921117	24	8	Germany Switzerland	National/ Reg.10	4	I11

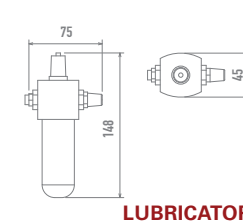
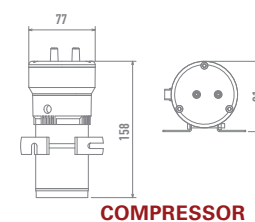

PS20 System

Through its powerful and directional sound, the priority system PS20 maximises security and sound localization of emergency vehicles. A pneumatic horn guided by an electronic module for continuous service, that guarantees a high duration.

El sistema prioritario PS20 maximiza la seguridad y la localización del sonido de los vehículos de emergencia. Avisador neumático guiado por un módulo electrónico para servicio continuo, que garantiza una duración elevada.

Il sistema prioritario PS20, dal suono potente e direzionale, massimizza la sicurezza e l'identificazione dei mezzi d'emergenza. Sirena pneumatica pilotata da una centralina elettronica per servizio continuo, che garantisce un'elevata durata.

Le système prioritaire PS20 maximise la sécurité et la localisation du son des véhicules prioritaires. Il s'agit d'un avertisseur pneumatique guidé par un module électronique pour service continu, qui garantit une durée élevée.

Das bevorrechtigte System PS20 maximiert durch ihren starken und gerichteten Klang die Sicherheit und die Schalllokalisierung der Notdienstfahrzeuge. Pneumatische, von einem elektronischen Modul geführte Hupe für den Dauerbetrieb mit erhöhter Dauer.

INTERNATIONAL Hi-Lo

- ITALY
- BELGIUM
- UK
- AUSTRIA
- GERMANY
- SWITZERLAND
- SPAIN



Electrovalves 12V / 24V

Trumpets

PS20 12V / 24V

Sounds / Suoni / Sonidos / Sons / Klänge
www.fiammcomponents.com/Horns

ELECTRONIC EMERGENCY HORNS AVVISATORI ELETTRONICI DI EMERGENZA AVISADORES ELECTRÓNICOS DE EMERGENCIA AVERTISSEURS ÉLECTRONIQUES ELEKTRONISCHE HUPEN

Flame retardant ABS Brass	PS20 KIT OF MODULE + 2 ELECTROVALVES	Voltage Voltaggio Voltage Tension Spannung	Amp. Draw Assorbimento Amperios Consummation Stromaufnahme	Compressed air source	Country	M O Q	Packaging
		V	A				u.
		12	1,5	On-Board air system Dedicated compressor	Italy	4	14
		12	1,5	On-Board air system Dedicated compressor	Italy	4	14
		24	0,7	On-Board air system Dedicated compressor	Italy	4	14
		24	0,7	On-Board air system Dedicated compressor	Belgium, UK International Hi-Lo	4	14
		12	1,5	On-Board air system Dedicated compressor	UK International Hi-Lo	4	14
		12	1,5	On-Board air system Dedicated compressor	Germany Switzerland	4	14
		12	1,5	On-Board air system Dedicated compressor	Austria	4	14
		24	0,7	On-Board air system Dedicated compressor	Germany Switzerland	4	14
		12	1,5	Dedicated compressor	Austria	8	S
		24	0,7	Dedicated compressor	Austria	8	S
		24	0,7	On-Board air system	Austria	8	S

Type approval / Omologazione / Homologación / Homologation / Zulassung
Reg. 10 / National homologation if required

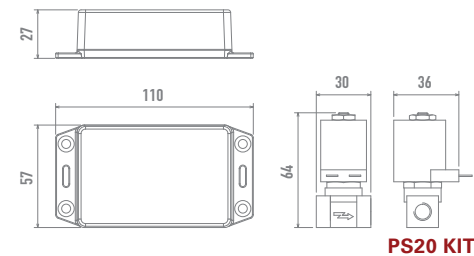

Trumpets

The trumpets on the MC4 and PS20 Systems, thanks to the chrome and coated versions, are easily installed both inside and outside vehicles. The frequency range covers various national standards. The 4-tone version offers maximum audibility and a pleasant sound.











Le trombe dei sistemi MC4 e PS20, grazie alle versioni cromate e verniciate si installano facilmente sia all'interno che all'esterno del veicolo. La gamma di frequenze copre le diverse normative nazionali. La versione a 4 toni rappresenta il massimo dell'udibilità e della piacevolezza del suono.

Las bocinas de los sistemas prioritarios MC4 y PS20, disponibles en versión cromada y pintada, se instalan fácilmente tanto dentro como fuera del vehículo. La gama de frecuencias cubre las diferentes normativas nacionales. La versión de 4 tonos se caracteriza por máxima audibilidad y un sonido agradable.











Les trompes des systèmes MC4 et PS20 grâce aux versions chromées et peintes s'installent facilement aussi bien à l'intérieur qu'à l'extérieur du véhicule. La gamme de fréquences répond aux différentes normes nationales. La version à 4 trompes et tons représente le maximum d'audibilité et du plaisir du son.

Die Hörner der MC4- und PS20-Systeme lassen sich dank ihrer Ausführung aus Chrom und Lack problemlos im Innern und außen am Fahrzeug installieren. Der Frequenzbereich deckt die unterschiedlichen nationalen Vorschriften. Die 4-Ton-Version bietet maximale Hörsamkeit und einen angenehmen Klang.

TRUMPETS TROMBE BOCINAS TROMPES HÖRNER

	Decibel Liv. sonoro Nivel sonoro Décibels Schallpegel	Frequency Frequenza Frecuencia Fréquence Frequenz	Country	H	M O Q	Packaging
	dB(A) 2m	Hz		mm	u.	
Metal						
						
TA SET OF 2 TRUMPETS						
 TA/2 906-V+SPOILER COD. 920392	117	L = 466 H = 622	Italy	286 210	8	H1
 TA/2 906-V+SPOILER COD. 920392	117	L = 466 H = 622	Austria	286 210	8	H1
 TA/2 906-V+SPOILER COD. 920392	117	L = 466 H = 622	Germany, Switzerland International	286 210	8	H1
 TA/2 906-C+SPOILER COD. 920393	117	L = 466 H = 622	Italy	286 210	8	H1
 TA/2 906-C+SPOILER COD. 920393	117	L = 466 H = 622	Austria	286 210	8	H1
 TA/2 906-C+SPOILER COD. 920393	117	L = 466 H = 622	Germany, Switzerland International	286 210	8	H1
 TA/2 VA-V+SPOILER COD. 920395	117	L = 392 H = 660	Italy	329 199	8	H1
 TA/2 GA-V COD. 920615	117	L = 494 H = 660	Netherlands	274 199	8	H1
 TA/2 GB-V COD. 920616	117	L = 440 H = 587	Netherlands	297 239	8	H1

TRUMPETS TROMBE BOCINAS TROMPES HÖRNER

	Decibel Liv. sonoro Nivel sonoro Décibels Schallpegel	Frequency Frequenza Frecuencia Fréquence Frequenz	Country	H	M O Q	Packaging
	dB(A) 2m	Hz		mm	u.	
Metal						
						
TA SET OF 2 TRUMPETS						
 TA/4 NL-C+SPOILER COD. 920647	117	L = 375 - 400 H = 485 - 500	Netherlands	275 - 283 374 - 389	3	F3
 TA/2 BL-C COD. 920629	117	L = 440 H = 494	Belgium	297 274	8	H1
 TA/2 BL-C COD. 920629	117	L = 440 H = 494	UK	297 274	8	H1
 TA/2 BL-V COD. 920396	117	L = 440 H = 494	Belgium	297 274	8	H1
 TA/2 BL-V COD. 920396	117	L = 440 H = 494	UK	297 274	8	H1
 TA/2 DE-B COD. 920397	117	L = 392 H = 523	Austria	329 262	8	H1
 TA/4 906-C+SPOILER COD. 920394	117	L = 435 - 450 H = 580 - 600	Germany, Switzerland International	297 - 289 223 - 214	4	H2
 TA/2 LE-V COD. 920400	117	L = 466 H = 544	Spain	286 251	8	H1
 SPOILER TA COD. 920618 ONLY SPOILER	-	-	All	-	8	S5

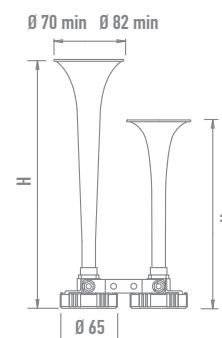

TA



VEGA line

Electromagnetic steel trumpets for excellent audibility at sea. Available in two-tones and pairs.



Bocina electromagnética de acero, de óptima audibilidad en el mar. Disponible en dos tonalidades, singularmente o en parejas.

Tromba elettromagnetica in acciaio dall'ottima udibilità in mare. Disponibile in due tonalità ed in coppia.

Trompe électromagnétique en acier, parfaite audibilité en mer. Disponible dans deux couleurs et en modèle double.

Elektromagnetische Hupe aus Stahl, die auf See besonders gut hörbar ist. Als Doppelhorn in zwei Farben erhältlich.

ELECTROMAGNETIC HORNS AVVISATORI ELETTROMAGNETICI AVISADORES ELECTROMAGNÉTICOS AVERTISSEURS ÉLECTROMAGNÉTIQUES ELEKTROMAGNETISCHE HUPEN

	Voltage Voltaggio Voltaje Tension Spannung	Amp. Draw Assorbimento Amperios Consummation Stromaufnahme	Decibel Liv. sonoro Nivel sonoro Décibels Schallpegel	Frequency Frequenza Frecuencia Fréquence Frequenz	M O Q u.	Packaging
Inox Steel	V	A	dB(A) 2m	Hz	u.	
VEGA						
						
VEGA 15 COD. 920333	12	6	117	370	6	F14
VEGA 18 COD. 920334	12	6	117	310	6	F14
Inox Steel						
VEGA DUAL						
						
VEGA DUAL COD. 920335	12	12	120	L = 320 H = 370	6	F13
VEGA DUAL COD. 920993	24	6	120	L = 320 H = 370	6	F13

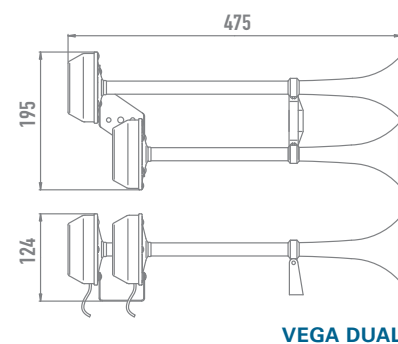
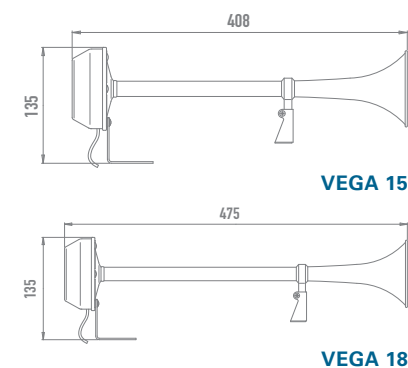

MARINE HORN line

Small electromagnetic emergency horn for retractable installation. Available in 5 colours.

Bocina electromagnética de dimensiones compactas para instalación retráctil. Disponibles con rejilla en 5 colores.

Avvisatore elettromagnetico di piccole dimensioni per installazione a scomparsa. Disponibile con griglia in 5 colorazioni.

Avertisseur électromagnétique de petite taille pour installation encastrable. Disponible avec grille en 5 couleurs.

Kleine elektromagnetische Hupe für eine versenkbare Installation. Mit Gitter in 5 Farben erhältlich.

ELECTROMAGNETIC HORNS AVVISATORI ELETTROMAGNETICI AVISADORES ELECTROMAGNÉTICOS AVERTISSEURS ÉLECTROMAGNÉTIQUES ELEKTROMAGNETISCHE HUPEN

	Voltage Voltaggio Voltaje Tension Spannung	Amp. Draw Assorbimento Amperios Consummation Stromaufnahme	Decibel Liv. sonoro Nivel sonoro Décibels Schallpegel	Frequency Frequenza Frecuencia Fréquence Frequenz	M O Q u.	Packaging
Steel / ABS	V	A	dB(A) 2m	Hz	u.	
MARINE HORN						
						
MARINE HORN BLACK - 2T COD. 920314	12	4,5	112	405	9	I6
MARINE HORN PANAMA - 2T COD. 920323	12	4,5	112	405	9	I6
MARINE HORN WHITE - 2T COD. 932216Z	12	4,5	112	405	4	G9
MARINE HORN STEEL - 2T COD. 932215Z	12	4,5	112	405	4	G9

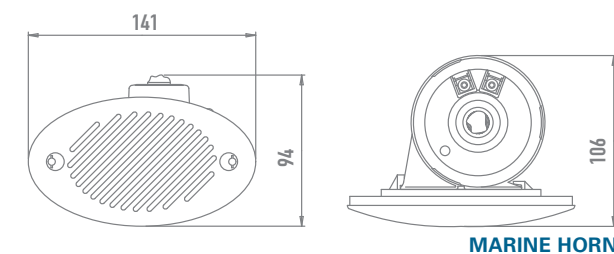

TA line

Electromagnetic steel trumpets for excellent audibility at sea. Available in two-tones and pairs.

Bocina electromagnética de acero, de óptima audibilidad en el mar. Disponible en dos tonalidades, singularmente o en parejas.

Tromba elettromagnetica in acciaio dall'ottima udibilità in mare. Disponibile in due tonalità ed in coppia.

Trompe électromagnétique en acier, parfaite audibilité en mer. Disponible dans deux couleurs et en modèle double.

Elektromagnetische Hupe aus Stahl, die auf See besonders gut hörbar ist. Als Doppelhorn in zwei Farben erhältlich.

PNEUMATIC HORNS AVVISATORI PNEUMATICI AVISADORES NEUMÁTICOS AVERTISSEURS PNEUMATIQUES PNEUMATISCHE HUPEN

Air consumption Consumo d'aria Consumo de aire Consummation d'air Luftverbrauch	Pressure Pressione Presión Pression Betriebsdruck	Decibel Liv. sonoro Nivel sonoro Décibels Schallpegel	Frequency Frequenza Frecuencia Fréquence Frequenz	M O Q u.	Packaging
l/sec	kPa	dB(A) 2m	Hz		

Inox Steel	NR/NS						
	TA/NR COD. 920310	1,2	100 400	120	380	6	F16
	TA/NS COD. 920311	1,2	100 400	320	380	6	F16
Inox Steel	DUAL						
	TA DUAL COD. 920336	2,4	100 400	123	H = 380 L = 320	6	F13
Inox Steel	MP						
	TA MP COD. 920374	5,5	400 800	128	380	5	F15

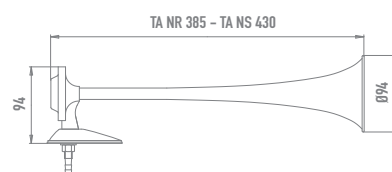

TA/NR - TA/NS

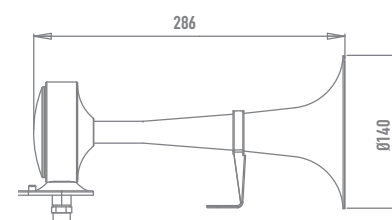

TA MP

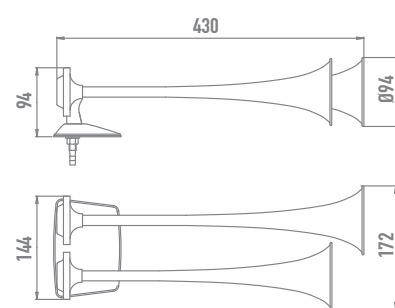

TA DUAL



ELECTROPNEUMATIC HORNS AVVISATORI Elettropneumatici AVISADORES ELECTROMAGNÉTICOS AVERTISSEURS ÉLECTROPNEUMATIQUES ELEKTROPNEUMATISCHE HUPEN

Voltage Voltaggio Voltaje Tension Spannung	Amp. Draw Assorbimento Amperios Consummation Stromaufnahme	Decibel Liv. sonoro Nivel sonoro Décibels Schallpegel	Frequency Frequenza Frecuencia Fréquence Frequenz	M O Q u.	Packaging
V	A	dB(A) 2m	Hz		

ABS	M4						
	M4/NR 12V COD. 921993 INOX STEEL	12	17	114	380	6	F10
	M4/NR 24V COD. 921994 INOX STEEL	24	8	114	380	6	F10
	M4/NS 12V COD. 921995 INOX STEEL	12	17	114	320	6	F10
	M4/NS 24V COD. 921996 INOX STEEL	24	8	114	320	6	F10

Adapters

ADAPTERS WITH ORIGINAL EQUIPMENT CONNECTOR
ADATTATORI CON CONNETTORI DI PRIMO IMPIANTO
ADAPTADORES CON CONECTOR DE EQUIPO ORIGINAL
ADAPTATEURS AVEC CONNECTEUR DE PREMIÈRE INSTALLATION
ADAPTER MIT ERSTAUSRÜSTER-ANSCHLUSS

Voltage Voltaggio Voltaje Tension Spannung	Suitable for Adatto per Adecuado para Approprié pour Geeignet für	M O Q	Packaging
V		u.	
			
-	IVECO / MERCEDES / OPEL RENAULT / VOLKSWAGEN	9	S2
-	ALFAROMEO / FERRARI / FIATFORD HOLDEN / JAGUAR LANDROVER LANCIA / OPEL VAUXALL / VOLVO	9	S2
-	ALFAROMEO / DACIA / FORD LANDROVER / MASERATI RENAULT / VOLVO	9	S2
-	CITROEN / PEUGEOT	9	S2

For 2 terminals connection



Relays available in 12V version to complete the electrical circuit
See pag.60

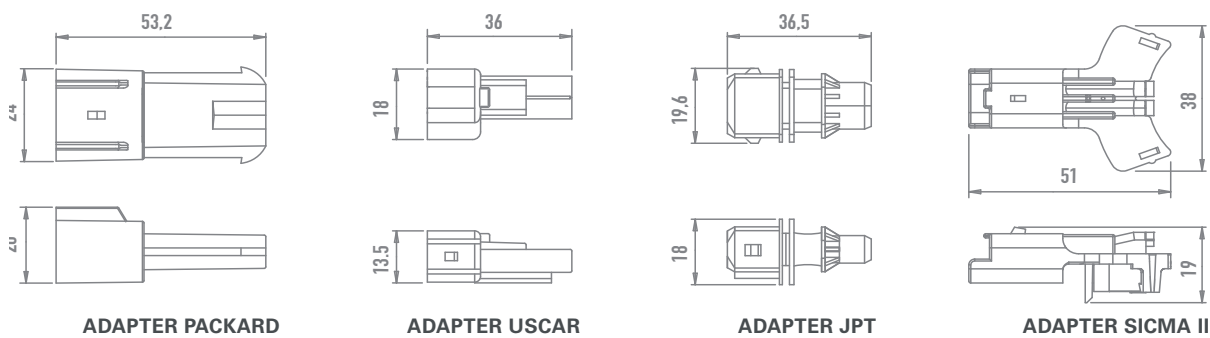

Connectors

